



Contents

General safety instructions

1.	Recommendations to be observed prior to the adjustments . . . . .	9
2.	Magnetic clutches for driving the machine arm and fabric rest plate . . . . .	11
3.	Height of the upper cloth clamps and position of the proximity switch b09 . . . . .	13
4.	Adjusting the cloth clamp pressure . . . . .	14
5.	Centre of pressure of the clamp actuating lever . . . . .	15
6.	Motion of the clamp closing lever . . . . .	16
7.	Position of the clamp closing lever . . . . .	17
8.	Lifting magnet for the clamp closing lever . . . . .	19
9.	Pre-adjusting the looper cam and tensioning the timing belt . . . . .	20
10.	Pre-adjusting the eyelet centre . . . . .	21
11.	Brake strap . . . . .	22
12.	Brake clamp . . . . .	23
13.	Automat end positions 1 cut after - 2 cut before . . . . .	25
14.	Roller bolt for regular distribution of stitches in the eyelet . . . . .	26
15.	Angular relationship of the looper block and fabric rest plate . . . . .	27
16.	Lateral adjustment of the fabric rest plate . . . . .	28
17.	Upper toothed quadrant . . . . .	29
18.	Clamping plates . . . . .	31
18.1	Parallel alignment to the fabric rest plate . . . . .	31
18.2	Adjusting the stopper pieces . . . . .	31
18.3	Adjusting the locking blocks . . . . .	31
18.4	Spreading the clamping plates . . . . .	31
18.5	Adjusting the upper cloth clamps . . . . .	31
19.	Symmetrical eyelet shape, eyelet centre and equal length of the buttonhole lips . . . . .	32
20.	Needle zero position . . . . .	33
21.	Cutting space between the two seam rows . . . . .	34
22.	Anvil body and cutting lever . . . . .	35
23.	Looper . . . . .	38
23.1	Adjusting the looper height . . . . .	38
23.2	Adjusting the loop stroke . . . . .	39
23.3	Needle bar height . . . . .	43
23.4	Looper - needle clearance . . . . .	43
24.	Needle guard . . . . .	44
25.	Spreader . . . . .	44
26.	Throat plate . . . . .	45
27.	Needle thread puller and tension release . . . . .	47



<b>Contents</b>	<b>Page</b>
28. Needle thread trimmer . . . . .	51
28.1 Control lever for the needle thread trimmer . . . . .	51
28.2 Needle thread knife . . . . .	51
28.3 Feed rod for the needle thread knife . . . . .	52
28.4 Lifting magnet for the needle thread knife . . . . .	53
29. Looper thread clamp on subclasses -112000, -113000 and -141000 . . . . .	55
30. Looper thread puller on subclasses -112000, -113000 and -141000 . . . . .	56
31. Trimmer for short looper thread on subclasses -112000 and -113000 . . . . .	57
32. Trimmer for short looper thread and gimp on subclass -141000 . . . . .	59
33. Gimp pulling device for subclass -141000 . . . . .	60
34. Cloth holder on subclasses -112000, -113000 and -141000 . . . . .	61
35. Mechanical needle thread catcher on subclasses -112000, -113000 and -141000 . . . . .	62
36. Trimmer for long looper and gimp threads on subclass -121000 . . . . .	63
36.1 Position of looper thread and gimp clamp . . . . .	64
36.2 Trimming pressure and motion of the looper thread and gimp trimmer . . . . .	65
36.3 Thread separator for looper thread and gimp . . . . .	68
36.4 Thread clamp and thread deflector . . . . .	69
36.5 Looper thread puller for the trimming action . . . . .	70
36.6 Looper thread puller for the secure seam beginning . . . . .	71
37. Grinding the thread trimmer knives . . . . .	72
38. Removing and mounting the machine arm . . . . .	75
38.1 Aligning the centres of rotation of needle bar and looper block . . . . .	80
39. Adjusting the synchronizer . . . . .	80
40. Electropneumatic needle thread catcher . . . . .	81
41. Electropneumatic looper thread puller for unwinding the looper thread from the thread stand	89
42. Electropneumatic looper thread laying device . . . . .	90



# 1. Recommendations to be observed prior to the adjustments

The technical data, installation, operation and maintenance of the sewing automat are described in the enclosed 578 instructions.

The present 578 service manual is a description of how to adjust the sewing automat in the appropriate order.

Do not forget that some adjustments are interdependent. For adjustments, therefore, always proceed in the described order.



**Warning: Risk of breakage!** After disassembly and before re-starting the sewing automat the pre-adjustments described in the sections 3, 4, 5, 9, 10 and 15 must be checked. If necessary, these adjustments must be made first. Do not turn the hand crank of the automat with fabric underneath and entered needle.



**Warning of personal injury!** If the clamp plates, cutting block, cutting knives, throat plate, and needle are not required to make the adjustments, they must be removed for safety reasons and to prevent breakage. The main switch should always be turned off, with the exception of adjustments that must be carried out with testing, adjusting and sewing programmes of the control box. **Attention!** Should the pedal be pressed down in sewing programme P01 by mistake, the automat is started.

For all adjustments on stitch-formation parts a new faultless needle must be inserted.

A set of gauges and various tools is available for the adjustments.

## Set of gauges, complete, order no. 578 2211

It consists of the following gauges:

Order no.	Use
557 604	Looper height
558 1633	2.0 mm thick and 10 mm wide for clamp spreading and cloth clamp height
558 1634	0.3 mm thick for air gap magnet clutches

## Tools:

Order no.	Designation
APP 53	Screwdriver 5.5
APP 56	Screwdriver 2.5
K993904247	Screwdriver F16kt SW3x200
558 1709	Screwdriver F16kt SW1.5
558 1710	Box spanner 8 mm
558 1711	Screwdriver FI 6kt SW6
5571347	Threading wire, short
K477110083	Threading wire, long

An adjustment needle is available under order no. 558 6060 by means of which the buttonhole seam pattern can be sewn on thin cardboard.

## Safety recommendations

Never remove or put any safety devices out of function.

If safety devices need to be removed for equipping, repairing or maintaining, the safety devices must be re-mounted directly after completion of the maintenance and repair work.

Unauthorized modification of the machine rules out liability of the manufacturer for damage resulting from this.

Observe all safety and danger recommendations on the machine/unit! The yellow-and-black striped surfaces designate permanent danger areas, eg danger of squashing, cutting, shearing or collision.

Besides the recommendations in this instruction manual also observe the general safety and accident prevention regulations!

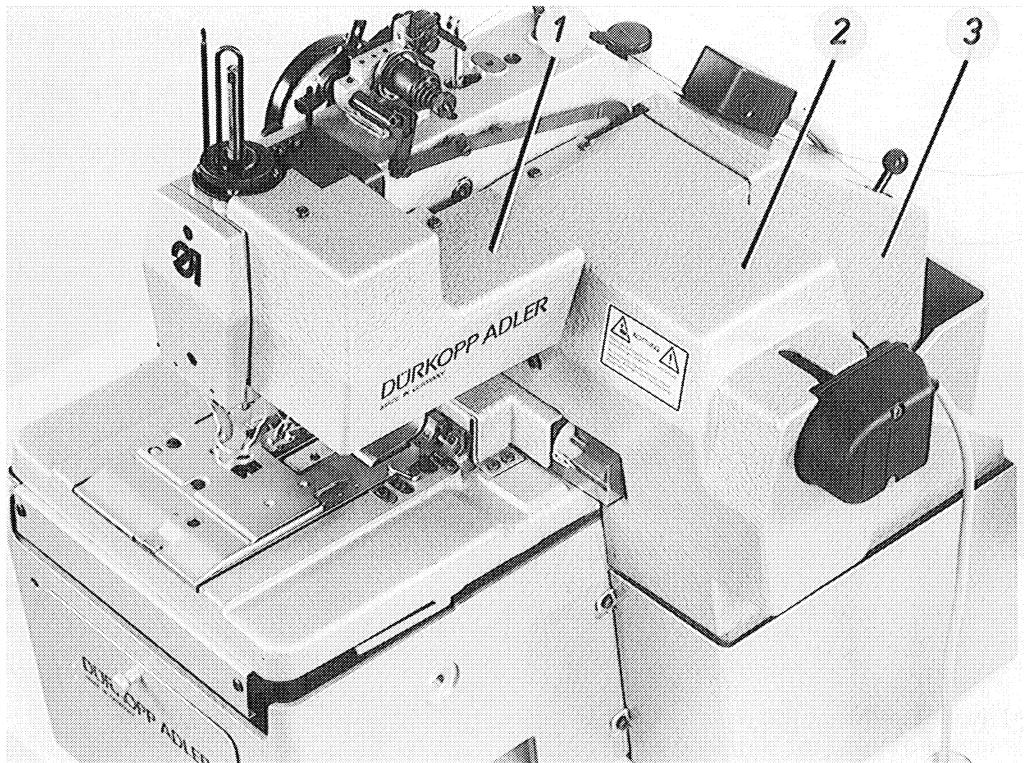
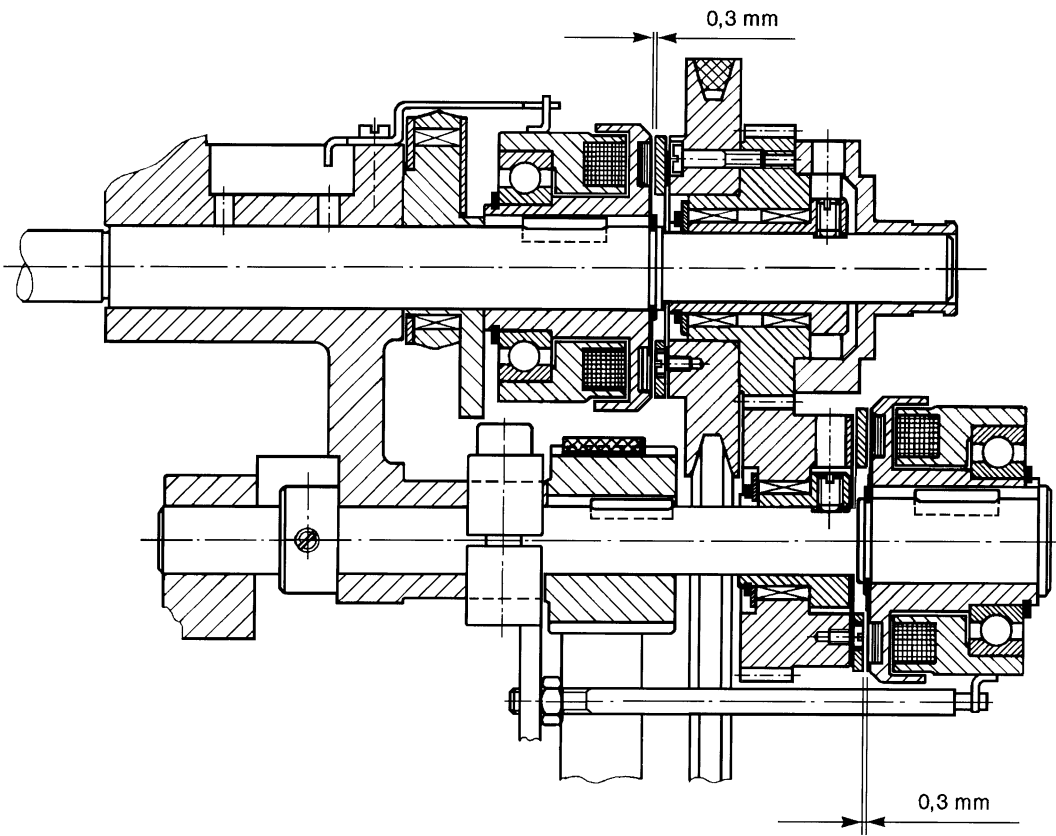



## 2. Magnetic clutches for driving the machine arm and fabric rest plate

After pressing the pedal the clutch 8 connects the transport of the fabric rest plate.

The needle bar is engaged by clutch 4 depending on the sewing length that is determined in the control.

With non-connected clutches the air gap between clutch part 5 and clutch disk 6 should be 0.3 mm.

- Turn off main switch.
- Remove the covers 2 and 3. (Cover 1 only exists on the -121000, otherwise optional equipment).

- Loosen the screws of the clutch disk 6 through hole 7.

Attention! The 1st screw in direction of rotation of the machine sits on the flat of the shaft.

- Adjust the clutch disk 6 with a distance of 0.3 mm to the clutch part. Clutch part 5 cannot be displaced. It is secured on the shaft by a circlip. For measurements use gauge 558 1634 with 0.3 mm thickness.
- Tighten the screws securely that are accessible through hole 7.
- Analogously adjust the clutch for the machine arm.

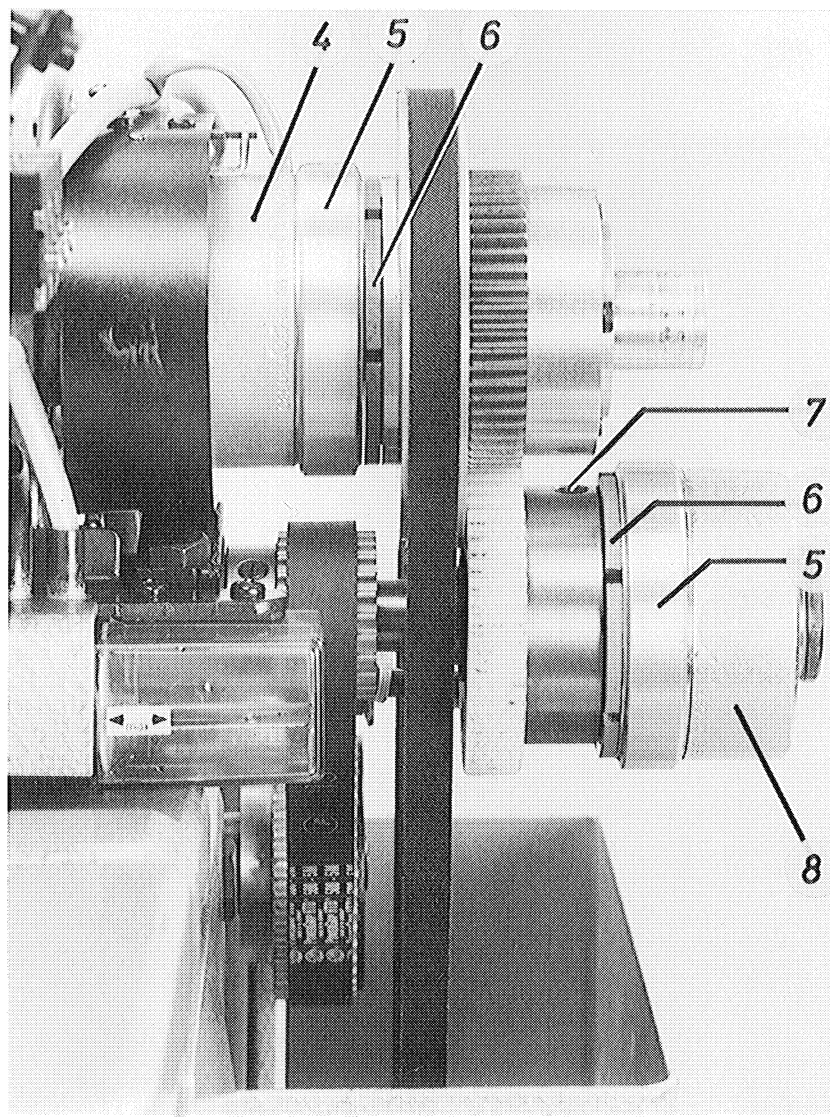

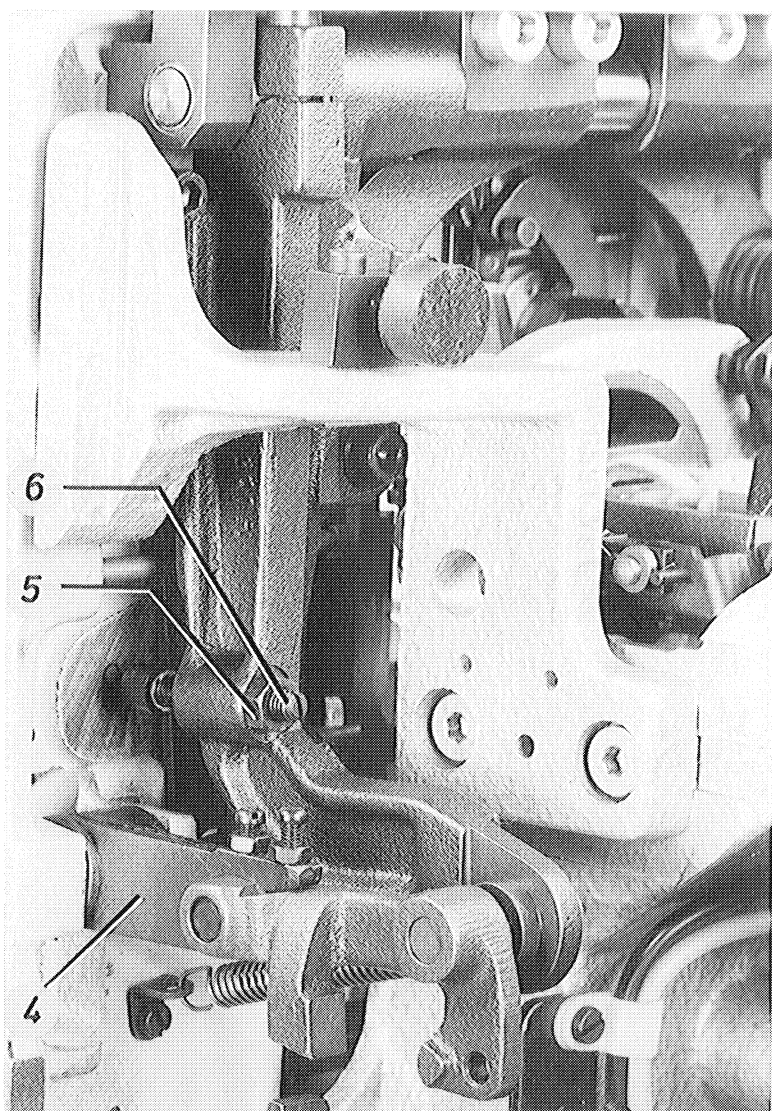
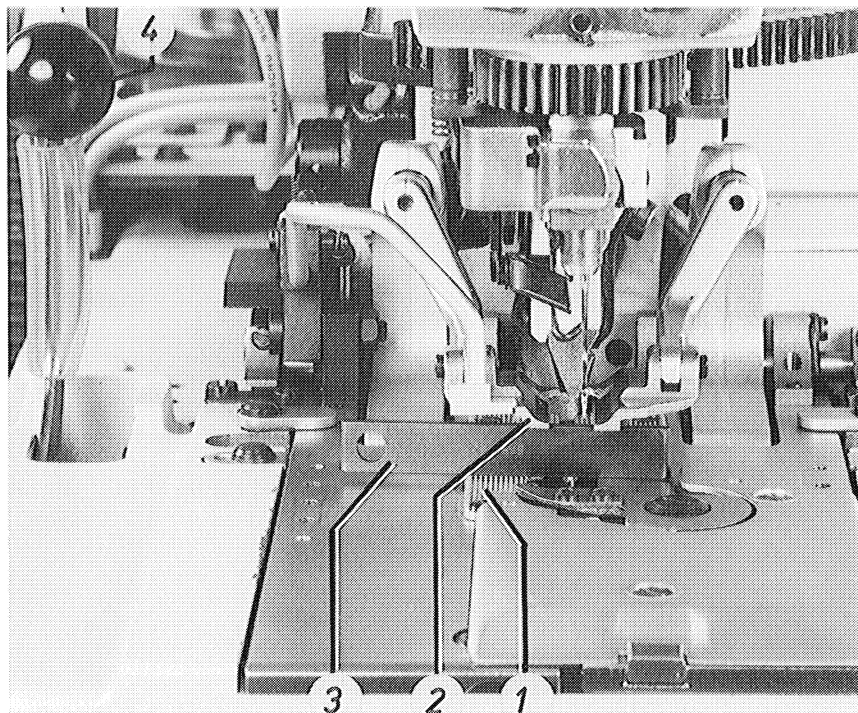



### 3. Height of the upper cloth clamps and position of the proximity switch b09



**Turn off main switch!**

The distance between the lower cloth clamps 1 and the upper cloth clamps 2 should be 10 mm.

For the safety system of the sewing automat the positional relationship of release sheet 8 and proximity switch b09 is very important.

In programme 63 with opened clamp actuator lever 4 the display should show status + and with closed clamp actuator lever status -.

– Loosen lock nut 5.

– Turn stop screw 6 accordingly. The cloth clamp height can be measured with the 10-mm-wide gauge 3, order no. 5581633.

– Tighten lock nut 5.

– Turn on main switch.

– Enter programme 63 at the switch "programme" of the control box and activate by STOP-push button.

Enter 09 for switch b09.

The status of the selected switch b09 is then shown on the display with + or -.

– Adjust stopper 7 with opened clamp actuator lever such that release sheet 8 is located before proximity switch b09 and status + (metal before switch) is shown on the display.

– The lateral distance between switch and release sheet should be 0.5 mm.

– Stopper 7 must be adjusted such that status - is shown when material is under the cloth clamps and the clamp actuator lever is closed.

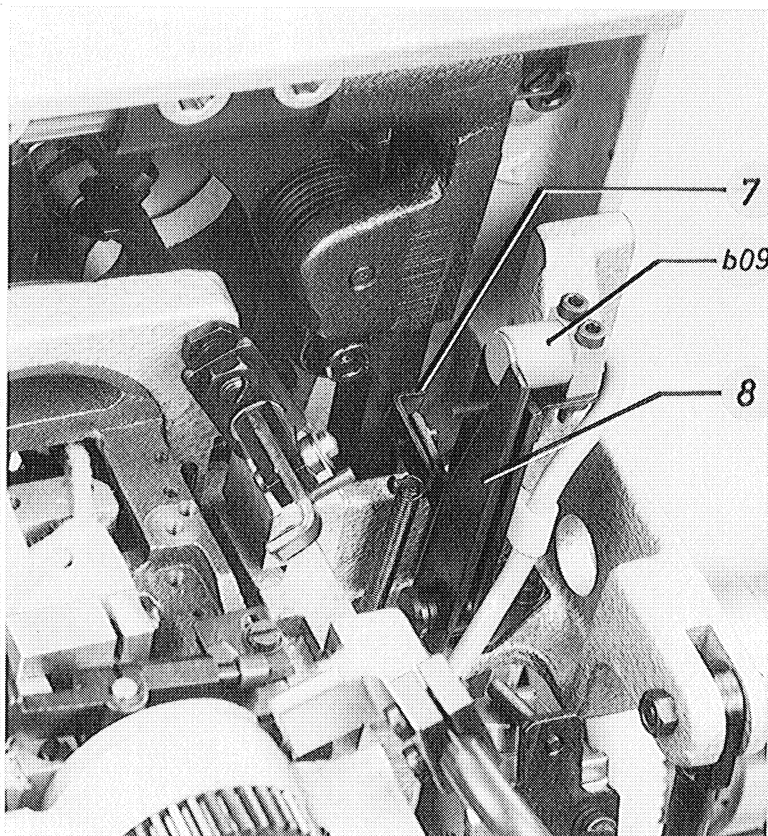



## 4. Adjusting the cloth clamp pressure



**Turn off main switch!**

The spring-mounted clamping frame 5 located under fabric rest plate 6 adjusts the pressure according to material thickness.

The pressure of its springs 3 was adjusted at the factory and must normally not be changed.

The distance between upper frame part 2 and lower frame part 4 should be 14.2 mm with a tolerance of up to + 0.5 mm. Adjustment is only possible with removed clamping frame.

Adjust the cloth clamp pressure such that even the thinnest fabrics are still clamped securely.

- Remove the upper cloth clamps. Caution! Make sure not to loose the inserted lock washers.

- Loosen the four clamping screws 1.
- Keep the clamp actuator lever 8 in its rear position.
- Place an object of 4-mm-thickness between the clamp bows 7 and the lower cloth clamps.
- Pull the clamp actuator lever 8 completely to the front.
- Tighten the four clamping screws 1 evenly. This provides the clamp pressure for a normal adjustment.
- Re-screw the upper cloth clamps. At the same time place the small lock washers in between.

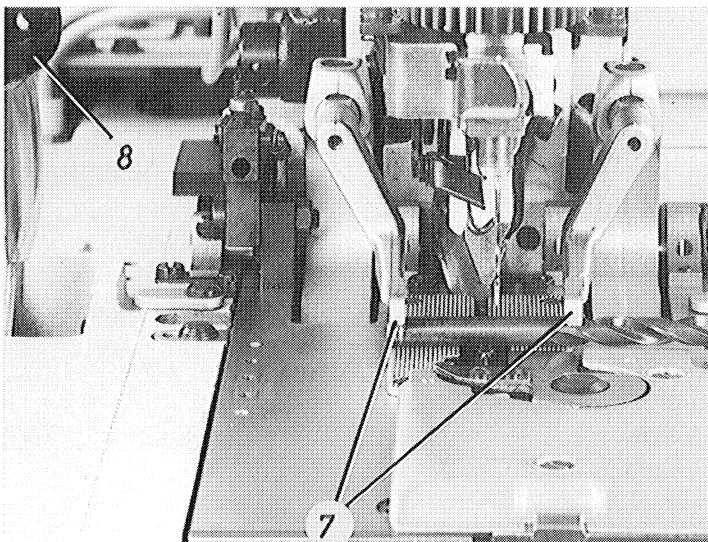
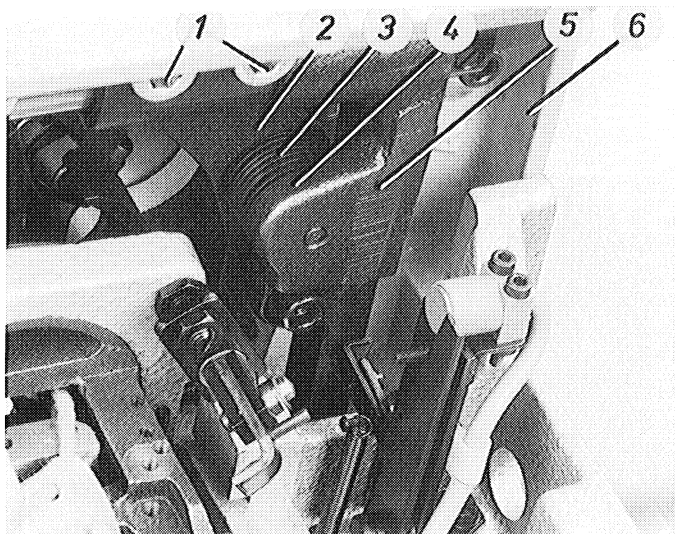



## 5. Centre of pressure of the clamp actuator lever



**Turn off main switch!**

To prevent the upper cloth clamps from opening during sewing, adjust the clamp actuator lever 2 such that it has slightly passed its maximum centre of pressure.

Adjust and check with positioned clamping plates.

Should the centre of pressure be passed too much, the result is an undesired reduction of the cloth

clamp pressure or the cloth clamps cannot be opened automatically by the clamp closing lever 1.

- After loosening the lock nut adjust the centre of pressure appropriately at set screw 3.

### **Note!**

The adjustments of pressure point and cloth clamp pressure are interdependent. If necessary, correct the cloth clamp pressure as described in section 4.

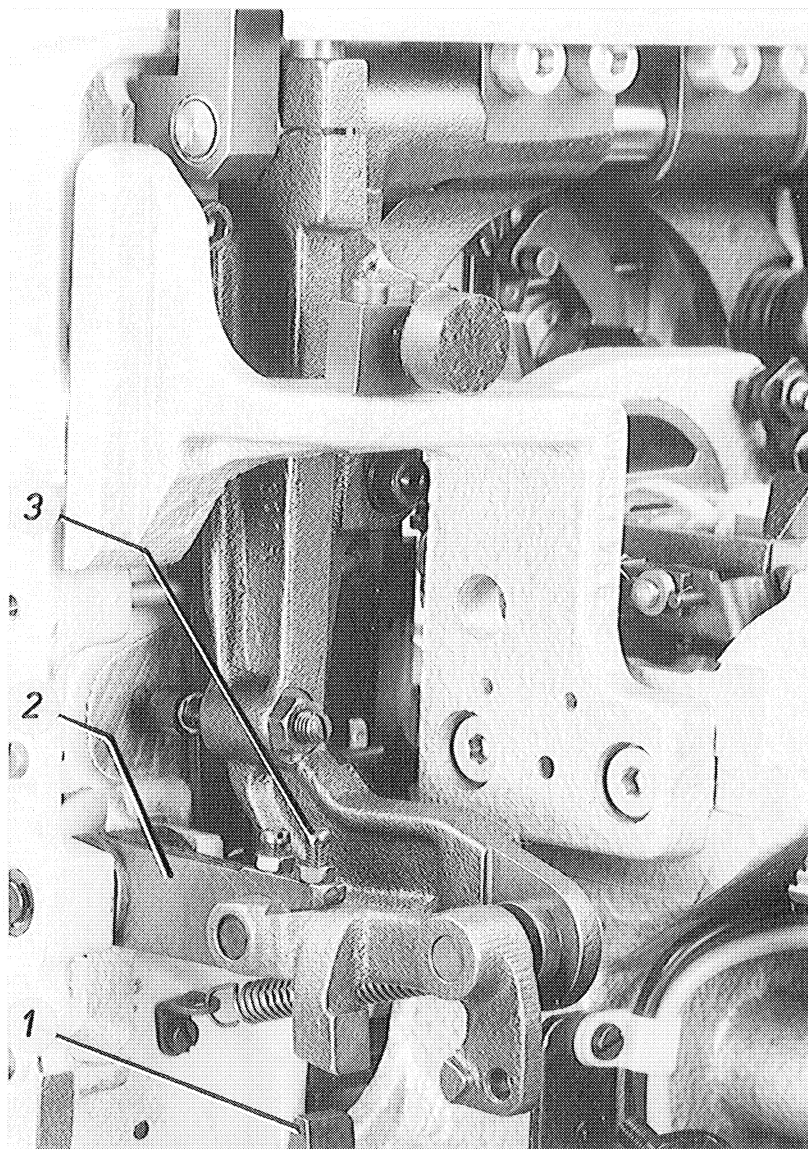



## 6. Motion of the clamp closing lever



**Turn off main switch!**

When the sewing automat is started the upper cloth clamps are automatically closed by the motion of the clamp closing lever 1.

To assure that the clamp actuator lever 6 is reliably moved up to the front of stop screw 5, in bottom position of closing contact 4 the distance between closing contact and angle lever 3 should be 0.1 mm.

- Turn the hand crank until closing contact 4 has reached its bottom position.
- Loosen screws 2.
- Set closing contact 4 at a distance of 0.1 mm.
- Tighten screws 2.

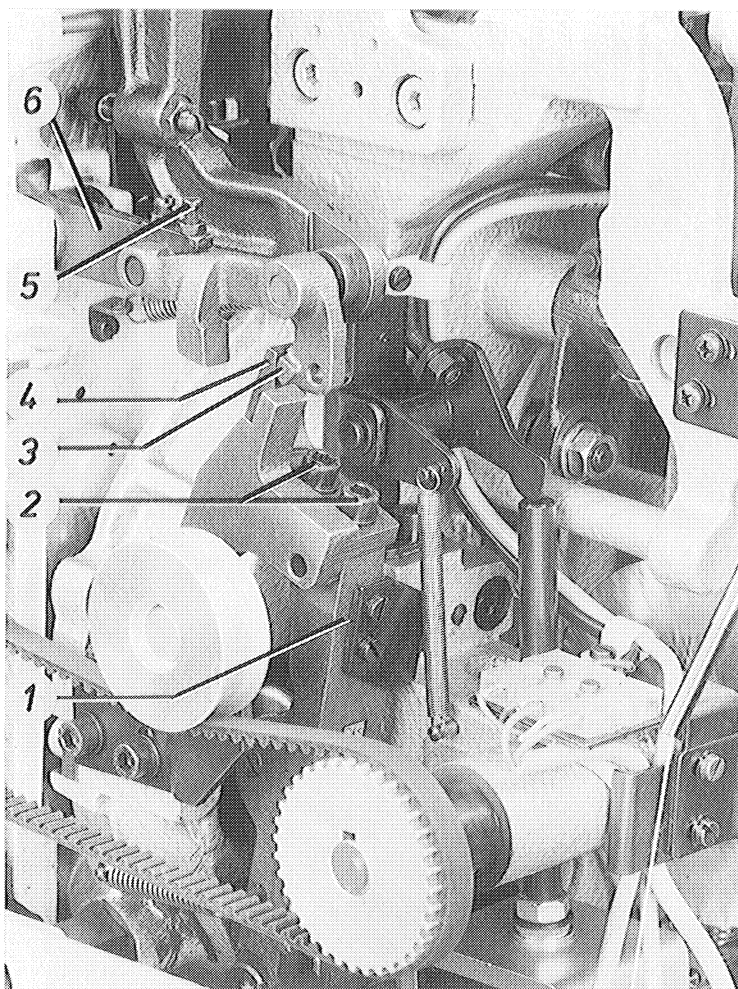



## 7. Position of the clamp closing lever



**Turn off main switch!**

The clamp closing lever is equipped with closing contact 4 for automatic closing and nose 2 for automatic opening of the clamping plates.

Depending on the sewing automat version

- a) cut before sewing
- b) cut after sewing or
- c) cut before and after sewing

this requires different positions of the clamp closing lever.

See table in section 23 for features of the subclasses.

### Re a) Cut before sewing

- With closed clamping plates turn the sewing automat with the hand crank out of its end position,

until the looper block has rotated by 360° and the looper thread tension 5 faces the front again.

- Before the clamp closing lever starts its downward motion that is, it runs up on the cam in the housing, set the nose 2 close to angle lever 3. For this, loosen screw 1.

### Re b) Cut after sewing

- With closed clamping plates turn the sewing automat with the hand crank out of its end position, until the looper block has rotated by 180°
- Turn further until the cutting lever descends and the cutting block is located above the knife.
- Loosen screw 1. Set the nose 2 close to the angle lever 3.

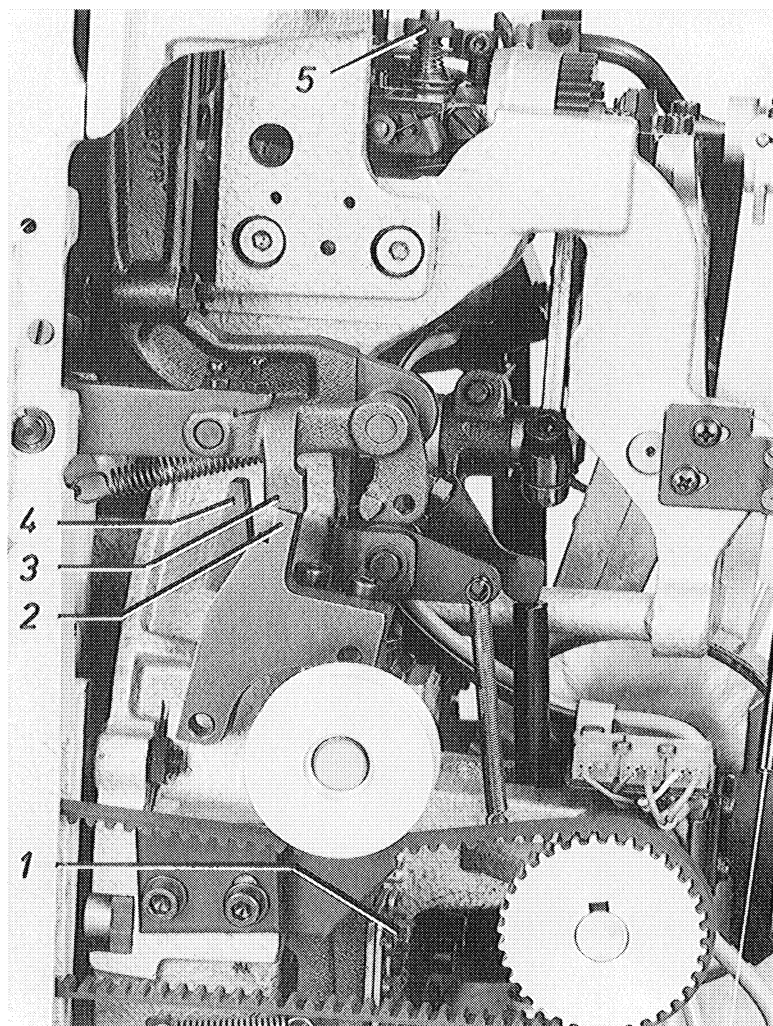



### Re c) Cut before and after sewing

In the case of sewing automats that are designed for cut before and after sewing two cams are located on the main control cam in the housing.

The 1st cam, seen in direction of rotation, does the closing motion for cut before sewing.

The clamp closing lever can be shifted between two stoppers that limit the positions for changeover of the sewing automat.

- First, proceed as described for cut before sewing under a).
- Shift stopper 2 completely towards N.

- With closed clamping plates turn the sewing automat with the hand crank out of its end position, until the looper block has rotated by 360° and the looper thread tension 4 faces the front again.
- Turn further until the downward closing motion of the clamp closing lever for cut before sewing starts.
- Turn further until the clamp closing lever moves up again.
- During this, point 6 of the nose must pass point 5 of the angle lever as closely as possible, but unhindered.
- For this, loosen screw 3 and set the clamp closing lever accordingly.
- To lock in this position shift stopper 1 completely towards V.

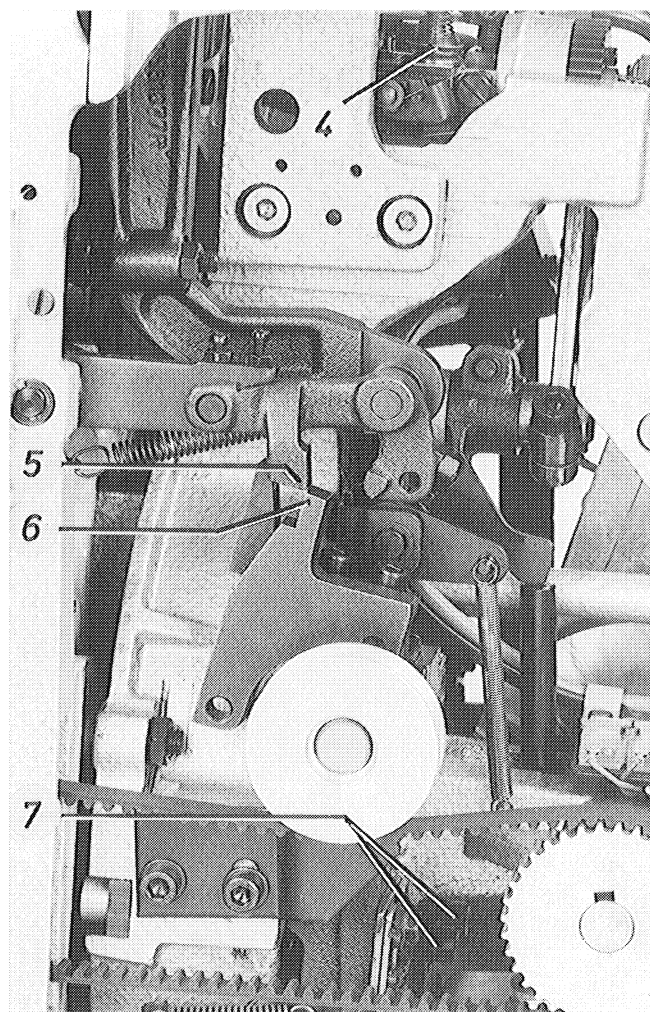
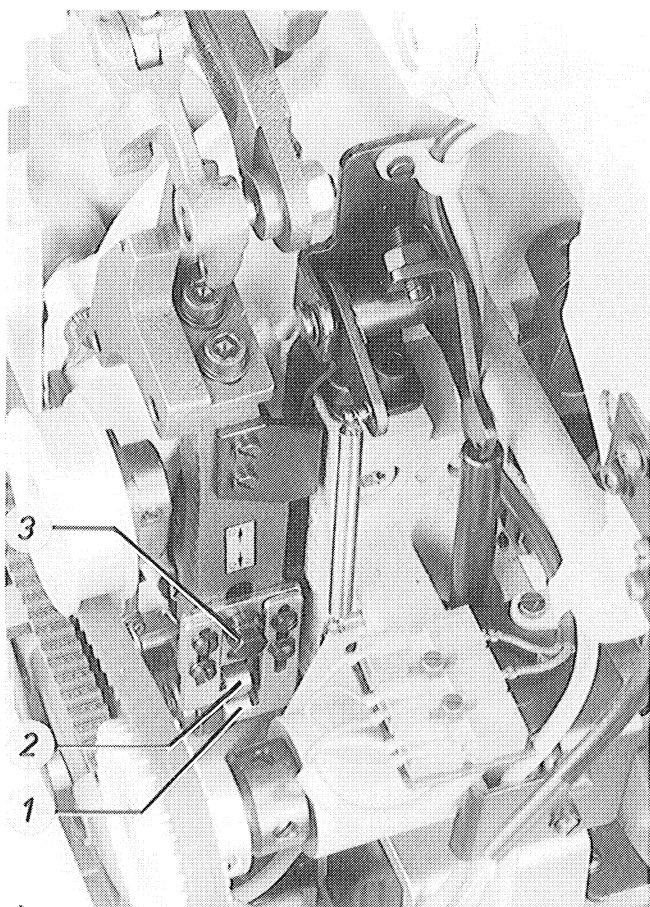



## 8. Lifting magnet for the clamp closing lever



**Turn off main switch!**

After pressing down the pedal until the 1st step, the lifting magnet 11 should close the cloth clamps until the clamp closing lever 8 is just before its centre of pressure.

For loading the piece it is thus at any time possible to open the cloth clamps after releasing the pedal.

After starting the automat, the cloth clamps are closed completely via the cam in the main control cam.

- Turn the sewing automat with the hand crank out of its end position such that the clamp closing lever 8 drops into the deepest point in the groove of the main control cam.

- Adjust a distance of 1 mm between the push rod 10 at bottom position and lever 9. Loosen screws 7 and adjust the height of the lifting magnet 11 accordingly.
- Turn the automat in end position using the hand crank.
- Turn on main switch.
- Actuate the lifting magnet in sewing programme P01 by pressing down the pedal until its 1st step.
- With extended push rod 10, turn the stop screw 12 and lock it with a nut such that the clamp closing lever 8 is just before its centre of pressure and the cloth clamps still open when the pedal is released.

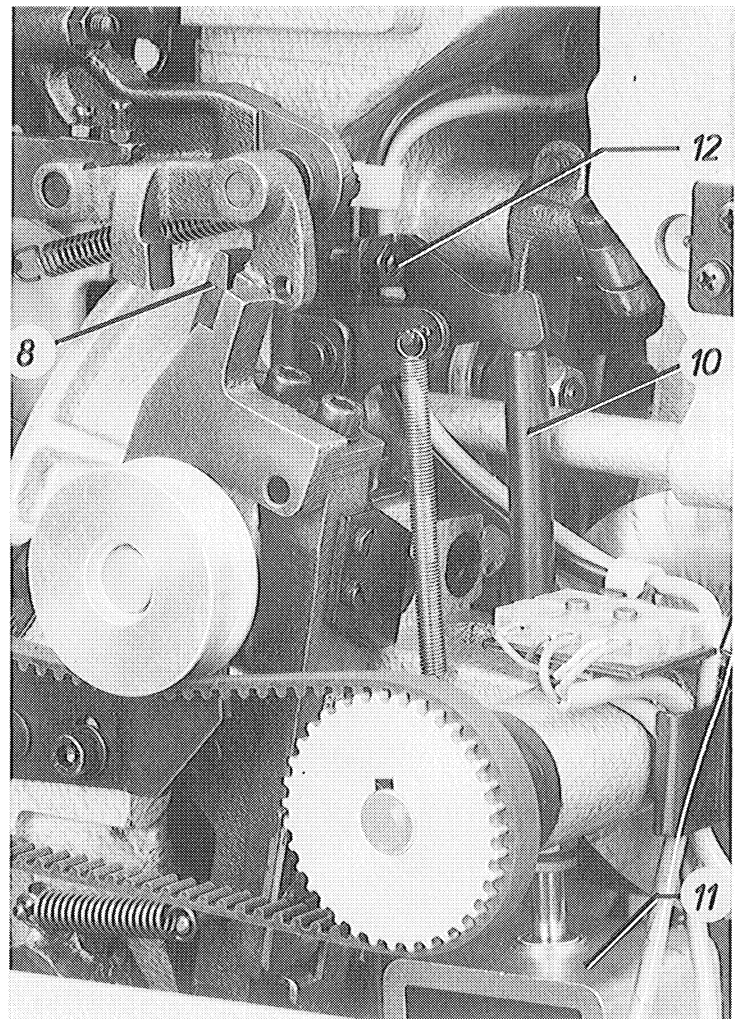
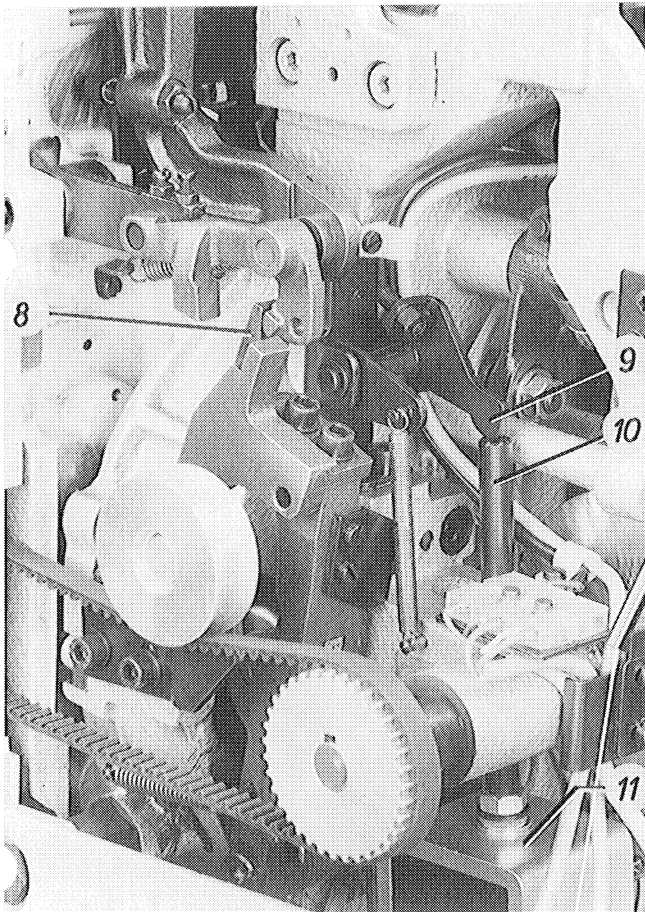



## 9. Pre-adjusting the looper cam and tensioning the timing belt



**Turn off main switch!**

During sewing of the right buttonhole lip and when the needle bar is in its up position above its left puncture, hole 2 of the looper cam 1 should be located in a horizontal line, as shown in the figure.

The exact adjustment procedure will be described in section 23.2 "Adjusting the loop stroke".

– Turn out screws 3 and remove belt tensioner 4.

- Remove the timing belt.
- Move the needle bar up and place it above its left puncture.
- Turn the looper cam into the described position.
- Position the timing belt and mount belt tensioner 4.
- Tension the timing belt so that the belt centre can be compressed by 6-8 mm by pressure of the finger.  
Tighten screws 3 securely.

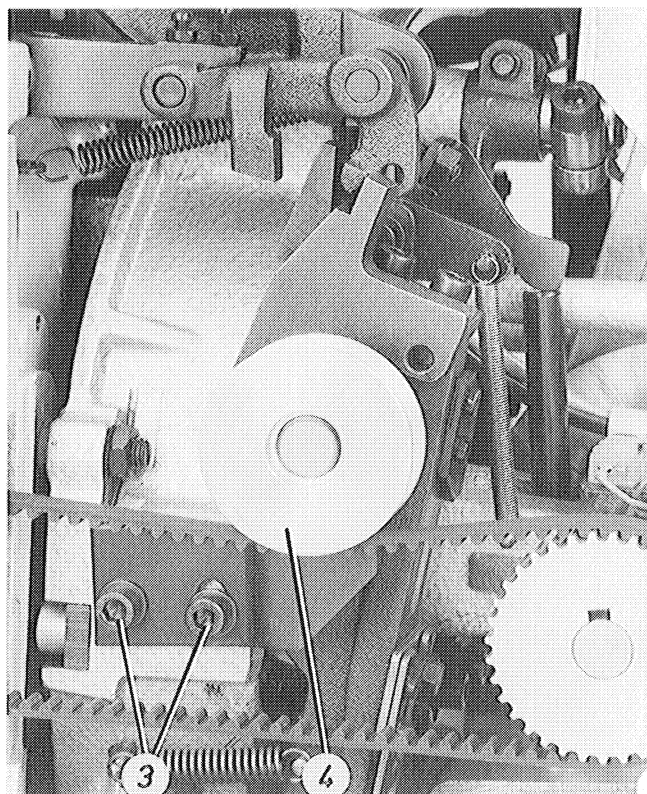
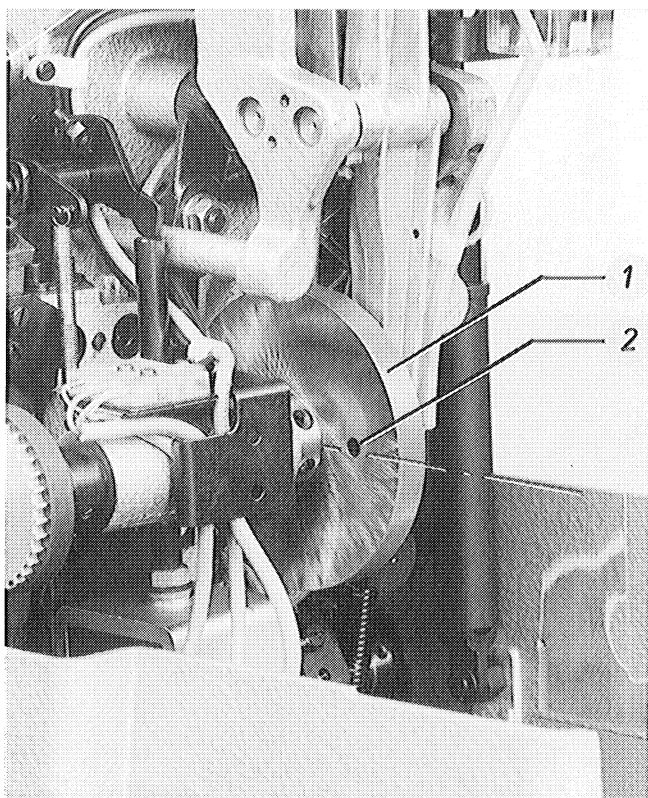



## 10. Pre-adjusting the eyelet centre



**Turn off main switch!**

For starting the automat and for further adjustments it is absolutely necessary to pre-adjust the control cams 2 and the shaft encoder 5.

If the automat is turned out of its end position using the hand crank until the looper block has rotated by 90° in the buttonhole eyelet, point 4 of the control cam for the eyelet shape should be located in front of roller bolt 3.

In this position and with activated programme 43 the shaft encoder 5 should show OK on the display.

For precise adjustment of the symmetrical eyelet shape and to thus assure an equal length of right and left lip proceed according to section 19.

- Remove cover 1.
- In 90° pos. of the looper block loosen screw 8.
- Turn plate 7 with the control cams until point 4 is located in front of roller bolt 3 as shown in the figure.
- Tighten screw 8.
- Loosen the two screws 6.
- Turn on main switch!  
Enter programme 43 at the switch "Programme" and activate by STOP-push button. Turn the shaft encoder until OK appears on the display.
- Tighten screws 6.

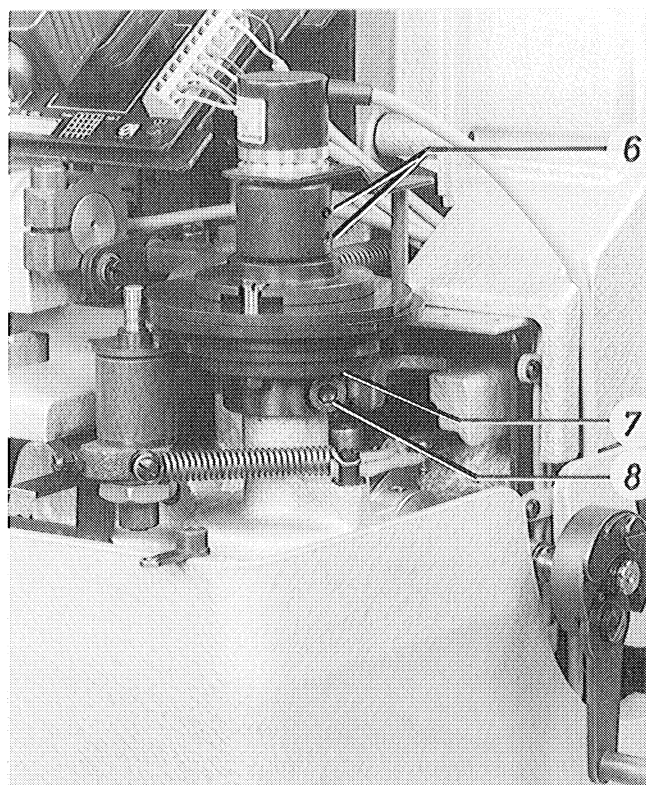
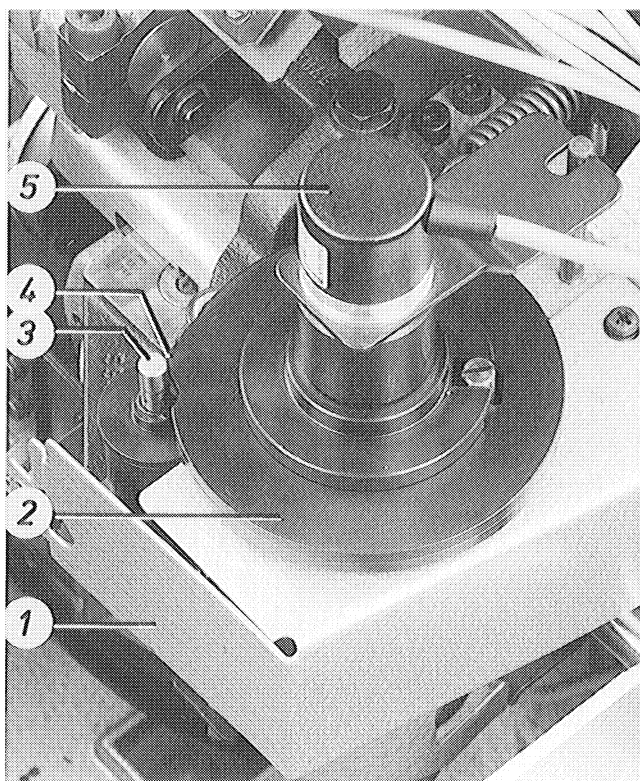



## 11. Brake strap



**Turn off main switch!**

The brake strap lies in a semi-circle around the main control cam in the front part of the housing.

The main control cam should only be slowed down so much that the stitch positions are regular in both seam rows.

If the brake strap is adjusted too loose, noise may result when sewing the buttonhole eyelet.

- Loosen brake clamps 3 by turning out pressure screw 2.
- First, it is advisable to turn the automat through one cycle with loosened brake strap using the hand crank. For this, loosen nut 1.
- Then, gradually tighten screw 2 and at the same time check the braking effect by turning the hand crank.
- Adjust the brake clamp 3 as described in section 12.

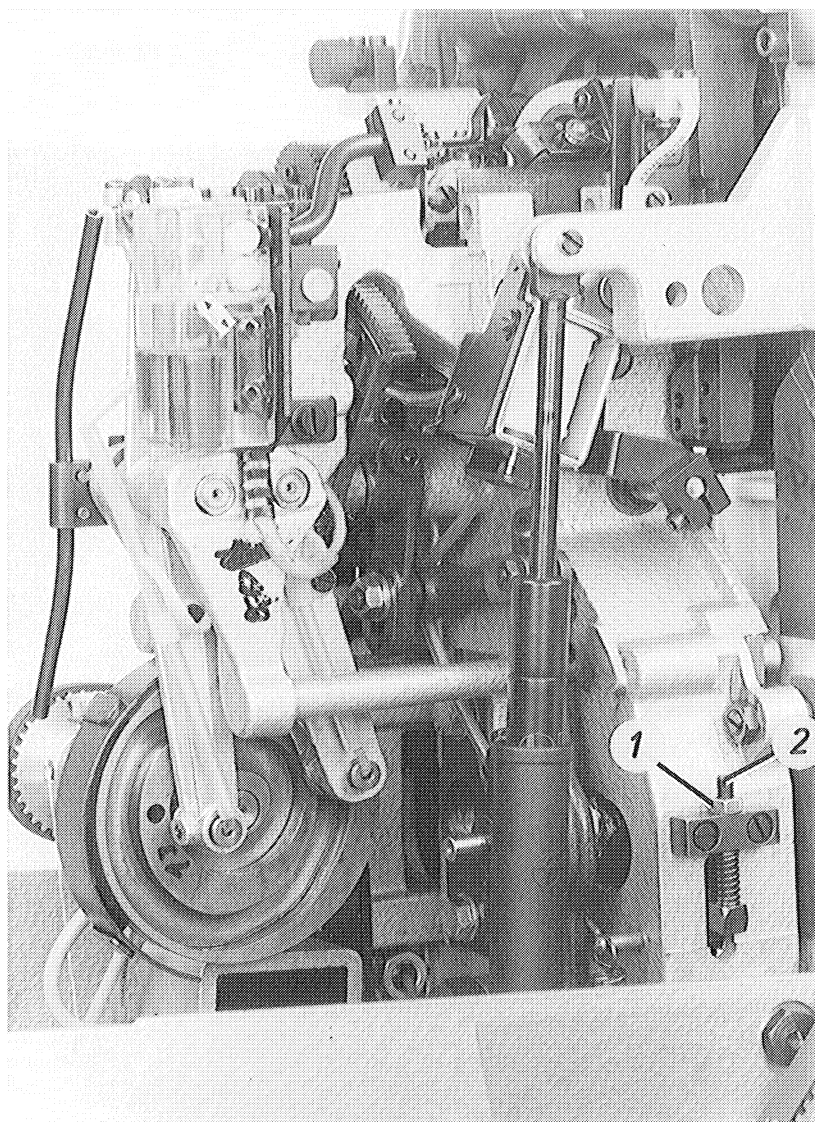



## 12. Brake clamp



**Turn off main switch!**

Purpose of the brake clamp 3 is to slow down the transport shaft 4 just enough to assure consistent transport of the fabric rest plate during operation of the automat.

To check, choose a position of the handwheel, where the fabric rest plate travels the longest transport path.

If the handwheel is turned in arrow-indicated direction, the locked hand crank will be moved further by a certain amount.

At the moment, when the hand crank stands still while the handwheel is being turned, the hand crank should not move back under slight pressure of, eg. two fingers.

It should be held in this position by the brake force of the brake clamps.

- Adjust the maximum transport length at the transport linkage.
- Adjust the pressure screw 2 accordingly and tighten the lock nut.

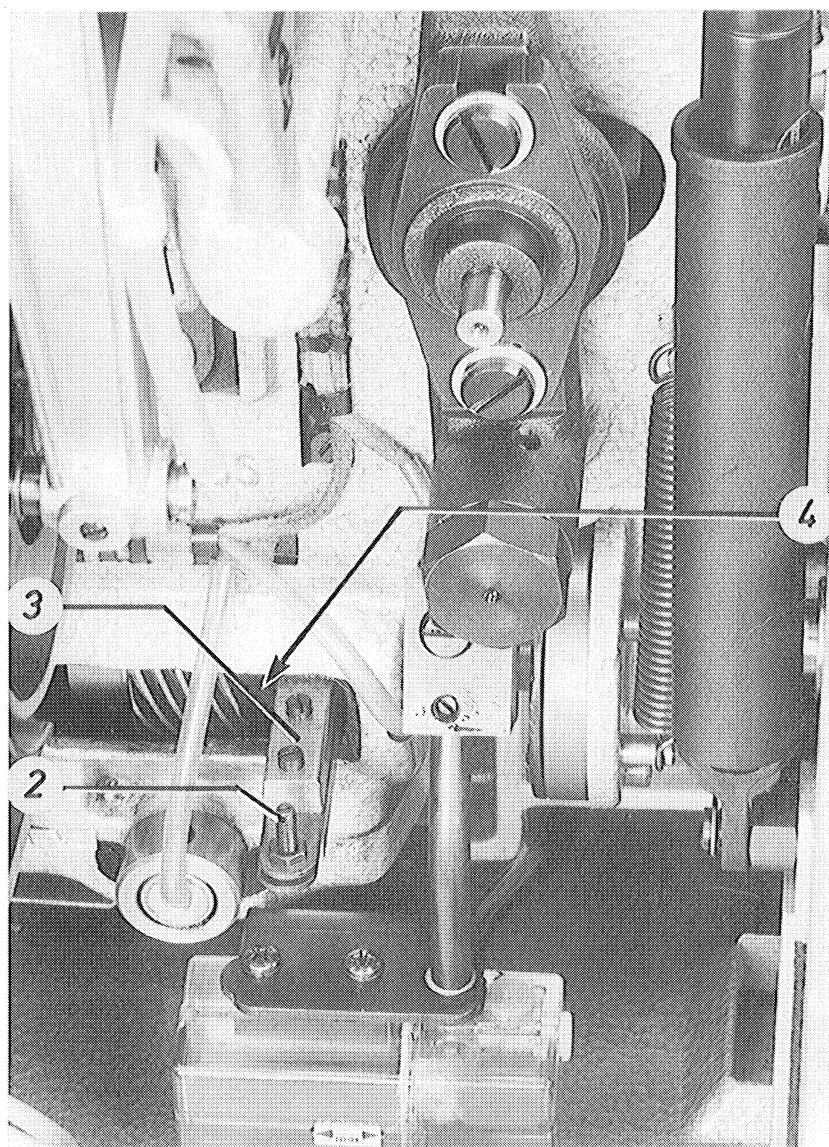

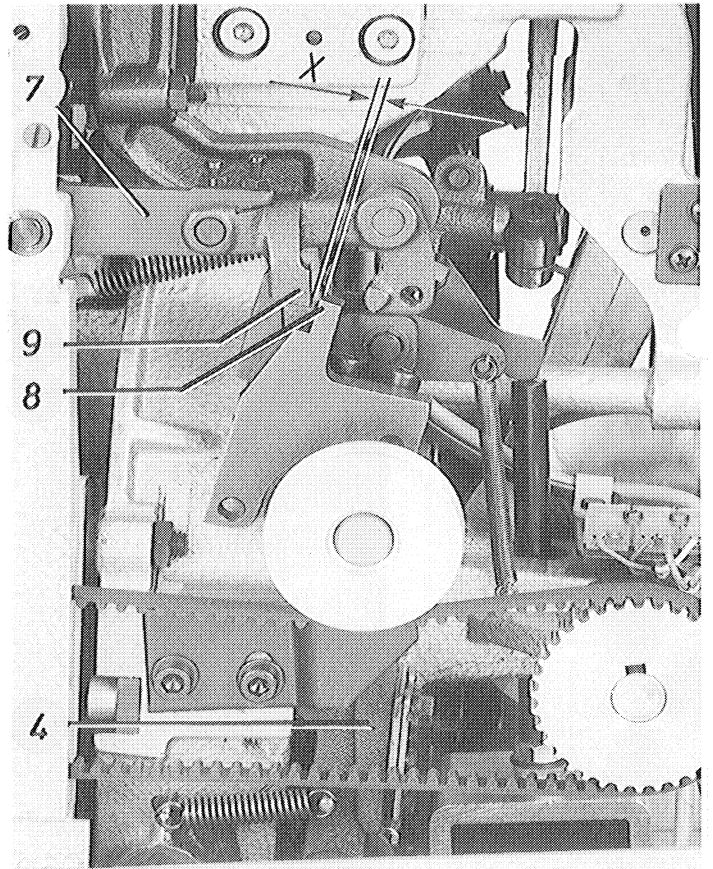
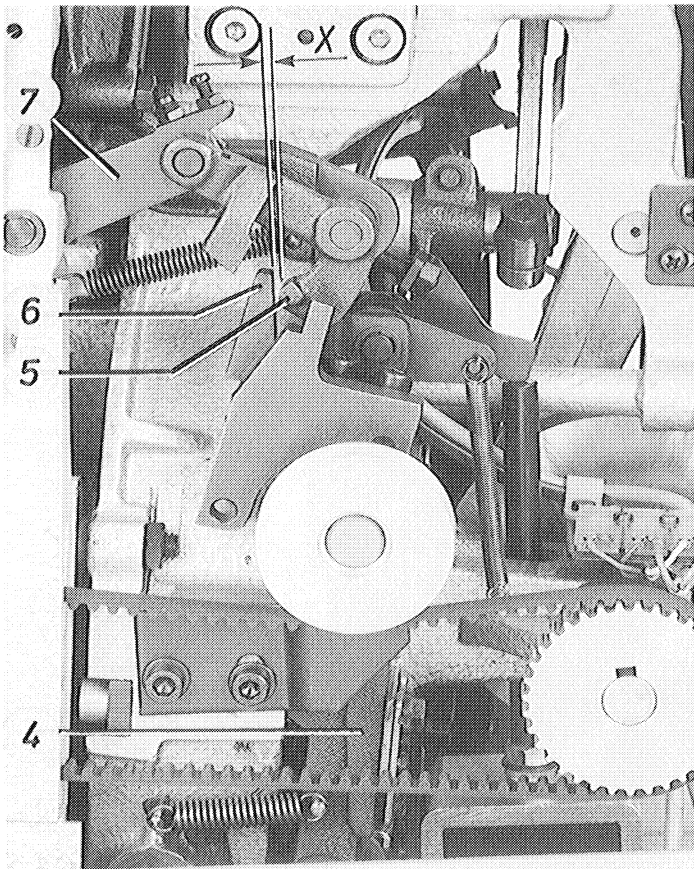
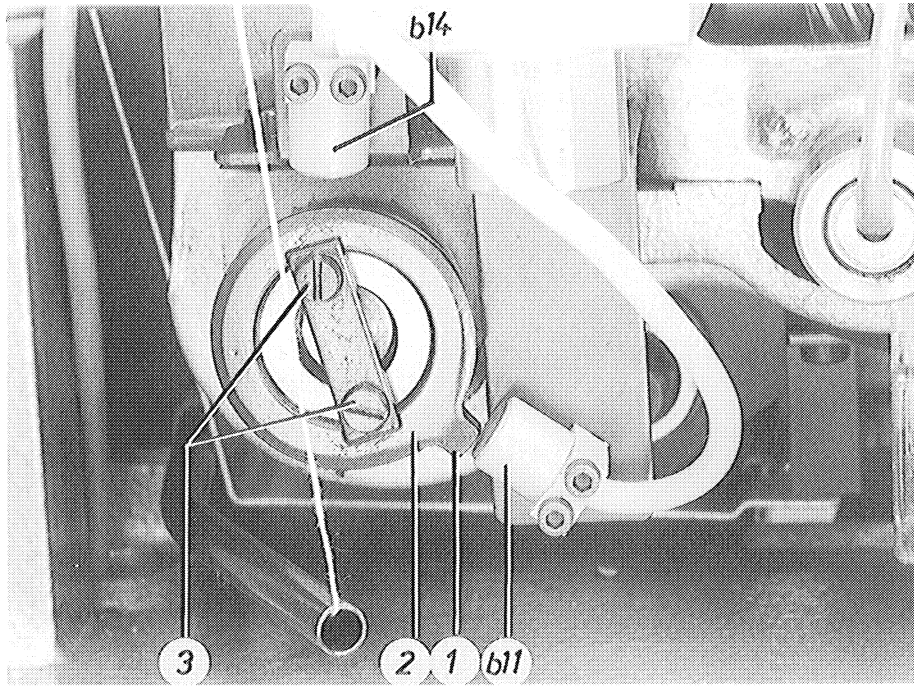



## 13. Automat end positions 1 cut after - 2 cut before



**Turn off main switch!**

The automat stops at the respective end position by means of the proximity switches b11 for cut after and b14 for cut before. The timing of the machine stop is determined by the position of the metal ring 2.

To adjust the metal ring it is necessary to bring the automat by hand, depending on subclass, to one of the end positions described below.

### End position 1 - cut after:

- The clamp closing lever 4 must be adjusted to cut after sewing as described in section 7.
- Turn the hand crank until the cutting motion of the cutting lever is completed.
- Turn further, until the clamps open and the clamp closing lever has reached a position with approx. the same distances x
  - a) between lever 5 and closing contact 6 **with opened** clamp actuating lever 7 and
  - b) between lever 9 and nose 8 **with closed** clamp actuating lever 7.

### End position 2 cut before:

- The clamp closing lever 4 must be adjusted to cut before sewing as described in section 7.
- Turn the hand crank until the looper block has completed its 180° rotation in the buttonhole eyelet.
- Turn further, until the cutting lever starts to descend slightly.
- In this position the clamp closing lever must be in a position, where the distances x described under a) and b) are obtained.

To adjust the respective end position proceed as follows by using the test and adjustment programmes:

### A) Subclasses for cut after sewing

- Turn the automat with the hand crank into its end position 1 - cut after as described above.
- Turn on main switch.
- Enter programme 63 at the switch "Programme" and activate by STOP-push button.
- Enter code no. 11 of the proximity switch b11 at the switch "Programme".
- In end position 1 nose 1 of the metal ring must be located above switch b11 with a distance of 0.5 mm.  
In this case the display shows status + for switch b11.
- When - is displayed, loosen screws 3 and set metal ring 2 with respect to switch b11.
- Enter programme 41 at the switch "Programme" and activate by STOP-push button. The display shows "End 1". Start a test run by pressing -key  $\Sigma$  "setting the counter".



**Caution! Automat moves with fast transport speed into its end position.**

- Check the end position 1 at automatic machine stop.  
If the distances x described above are not yet reached with opened or closed clamp actuating lever, correct the position of metal ring 2 accordingly.

**Note!** On subclasses that are designed only for cut before or cut after sewing, both switch b11 and switch b14 are required to assure proper enquiry by the control.

### B) Subclasses for cut before sewing

- Adjustments are made analogously as described above in end position 2 - cut before and at switch b14.
- The test run may be started in programme 42.

### C) Subclasses for cut before and after sewing

- Here, make both adjustments, as described under a) and b).
- To make both adjustments accurately, switches b11 and b14 can be loosened and shifted within their fastening holes to slightly increase or decrease the switching sector.



## 14. Roller bolt for regular distribution of stitches in the eyelet

To obtain an even distribution of stitches in the eyelet, the rotary motion of looper block and needle bar must be synchronous with the turning point of the fabric rest plate that is, the looper block should rotate by 90° before the turning point of the fabric rest plate and by 90° after this point.

The adjustment was made at the factory. The fastening screws 2 for the roller bolt 1 are, therefore, sealed with yellow lacquer.

An adjustment is only necessary after disassembly, eg exchange of a main control cam.

The distribution of eyelet stitches can be checked on thin cardboard, using a short adjustment needle, order no. 558 6060.

When the roller bolt 1 is shifted, the adjustments described in sections 15, 16 and 17 must be repeated.

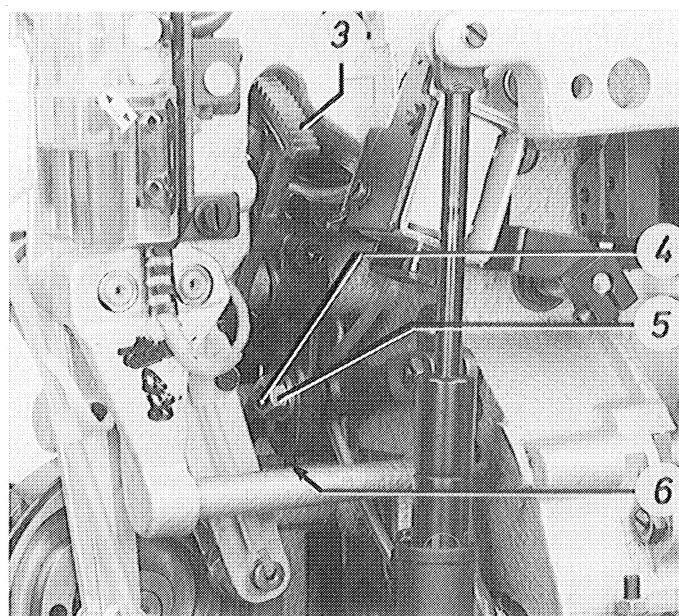
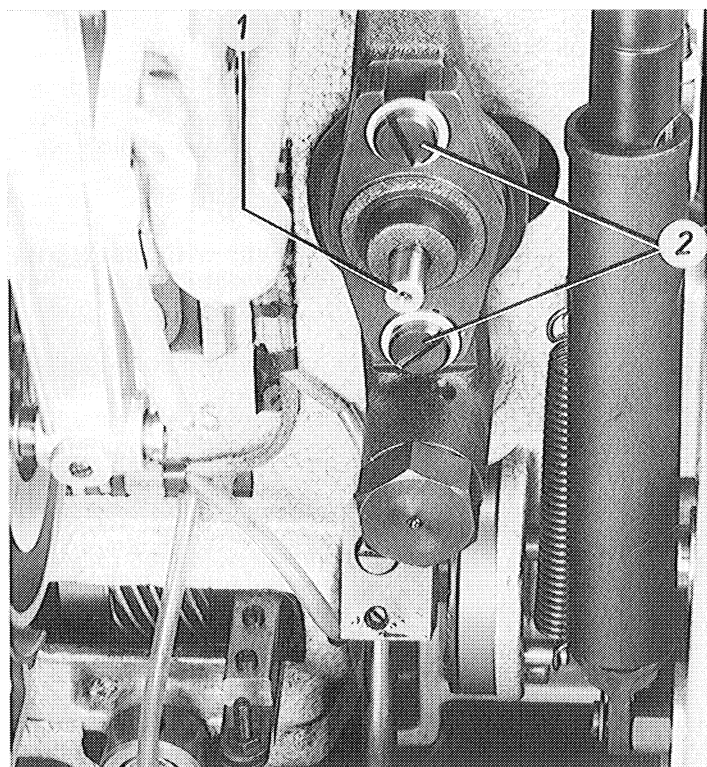



## 15. Angular relationship of the looper block and fabric rest plate

The looper block must be located at a right angle to the fabric rest plate during sewing of both button-hole lips that is, also after a rotation of 180° in the eyelet.

The measurement with an angle, see figure, should not be made in end position, but approx. at the centre of the right and left lip.

With the exception of subclass -114000.

Here, the 1st measurement should be made in end position and the 2nd after the seam end, before the looper block starts to rotate into its end position.

- Remove the clamping plates and close the clamp actuating lever.
- Loosen screws 8 and remove the spreader stops, spreaders and looper.
- Remove the throat plate, cutting block, cutting knife and after loosening screw 9, the knife lever with needle thread knife.
- Turn on main switch.
- Start the automat via pedal and then stop it by heeling back, when approx. the middle of the right buttonhole has been reached.

- As shown in the figure, set the angle against the looper block and check the position of the angle with respect to edge 7 of the fabric rest plate.
- Re-start the automat and after a looper block rotation in the eyelet stop it approx. at the middle of the left lip.
- The angle should have the same position to edge 7 that is, the looper block should rotate by exactly 180°.
- Loosen nut 5 (see fig. left side) and adjust the accurate rotation of 180° by shifting bolt 4 up or down.
- It is advisable to use set screw 6 for adjustments, as the bolt in most cases must only be shifted slightly. Check the adjustment after a test run of the machine.
- If the angle is parallel to edge 7 in both positions of the looper block, loosen the screw of the toothed quadrant 3 and set the looper block at a right angle to edge 7.

### Note!

In both positions of the looper block an equal amount of teeth of the toothed quadrant must mesh with the gear.

In the case of incorrect meshing swivel the toothed quadrant sideways and set accordingly.

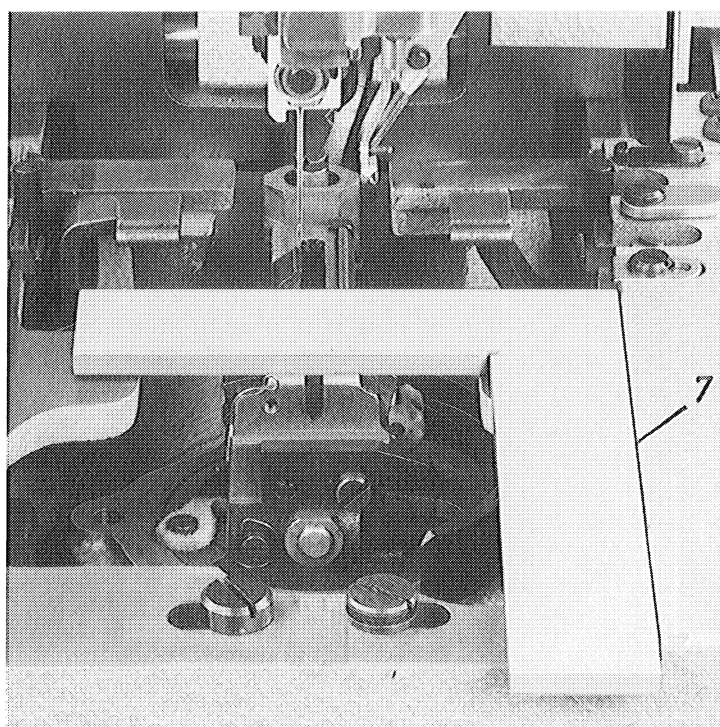
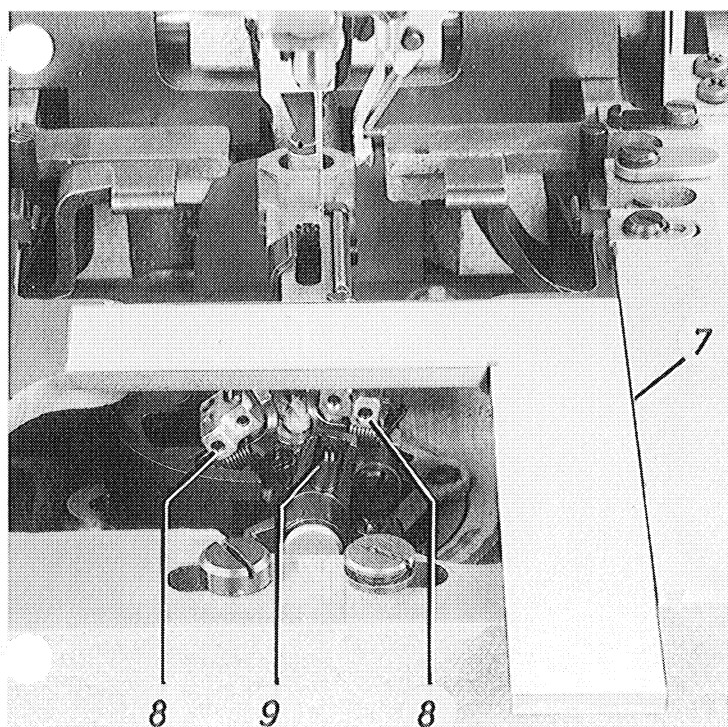



## 16. Lateral adjustment of the fabric rest plate



**Turn off main switch!**

The distances  $x$  and  $x_1$  between the edges of fabric rest plate and looper block must be equal.

To adjust this, turn the automat with the hand crank slightly out of its end position, until roller bolt 7 slips off cam 3 and rests against the above control cams 6.

- Use a slide gauge to compare the distance  $x$  to edge 1 and the distance  $x_1$  to edge 2.

- In the case of unequal distances loosen nut 4.
- Set the roller bolt accordingly using set screw 5.
- After tightening nut 4, run the automat through one cycle, then turn the automat **out of its end position** and check the adjustment again.
- Lock the set screw 5 with a nut.

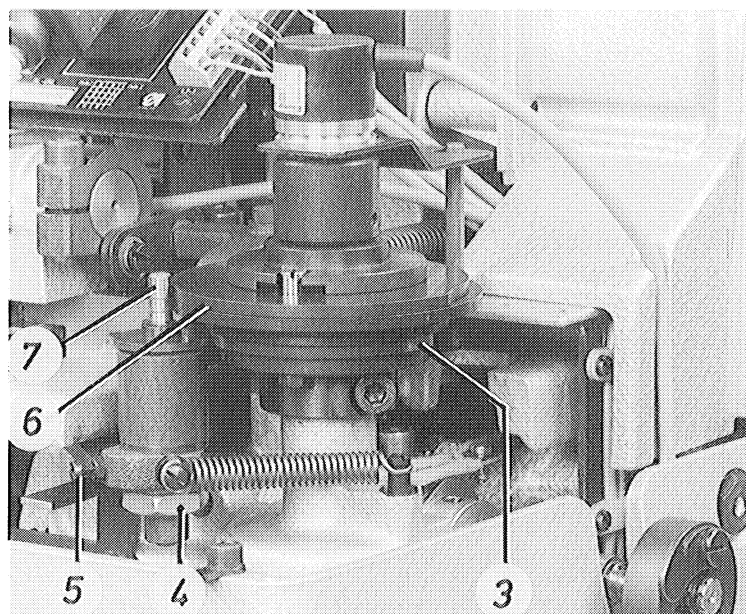
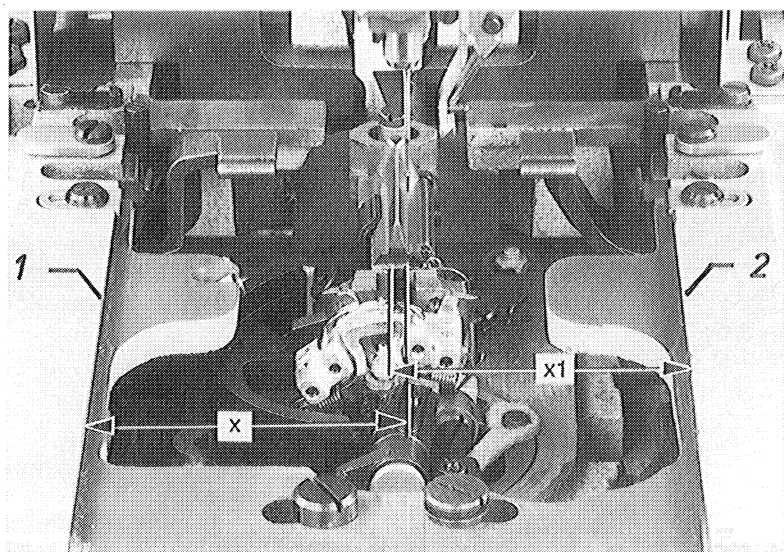



## 17. Upper toothed quadrant



**Turn off main switch!**

Before adjusting the upper toothed quadrant 1 the adjustments described in sections 14, 15, and 16 must have been correctly made or checked.

The needle bar should oscillate exactly at a right angle to the fabric rest plate.

- Loosen screw 3. Turn toothed quadrant 1 on axis 2 such that oscillation bushing 5 is located parallel to edge 6 of the fabric rest plate.

- Turn on main switch.

When the automat has finished a cycle, place a slide gauge or ruler at oscillation sleeve 5 to make the measurements. Make sure not to position it across bolt 4.

### **Note!**

An equal number of teeth of the lower toothed quadrant as well as of the upper toothed quadrant must mesh in both end positions, when the oscillation bushing is located parallel to the fabric rest plate.

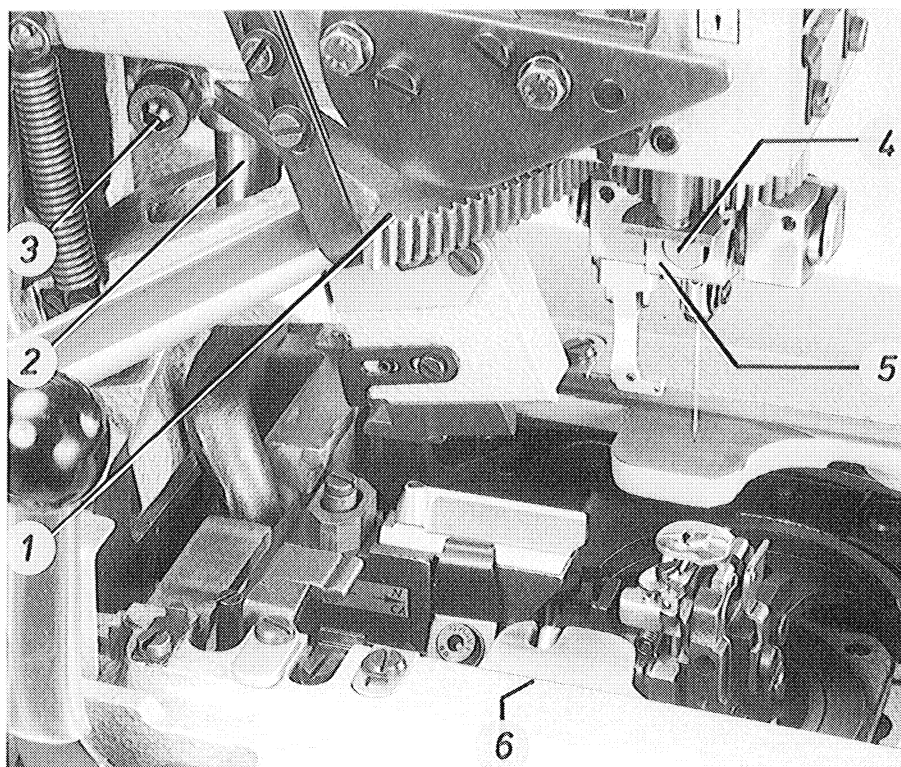

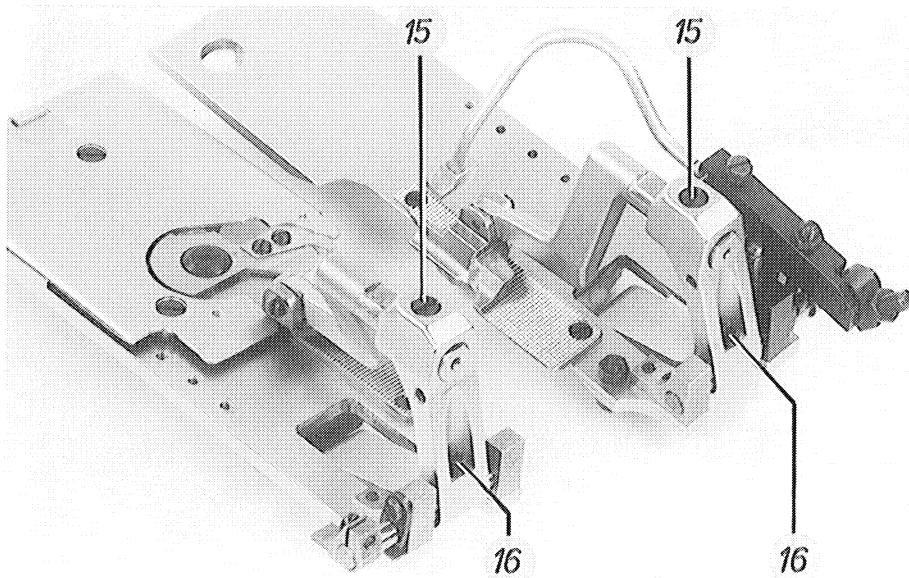
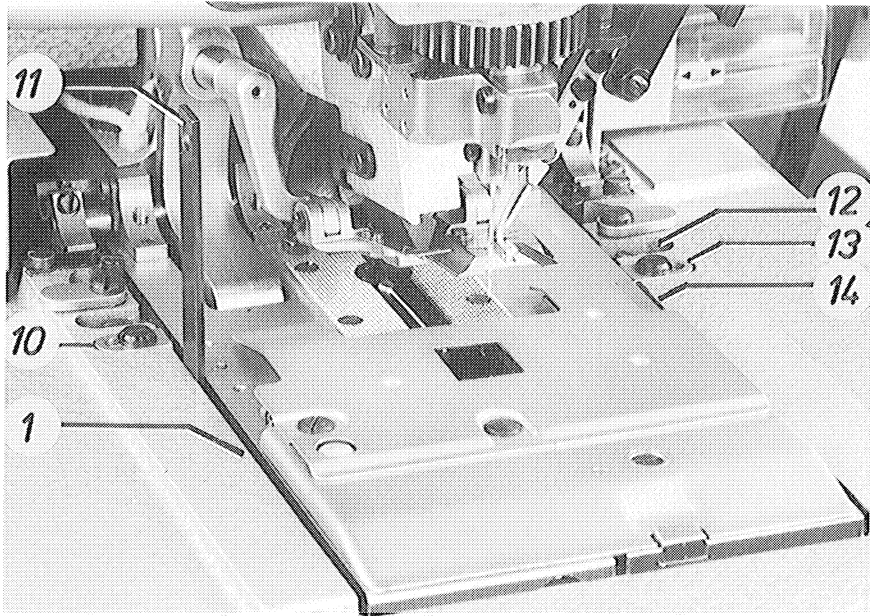
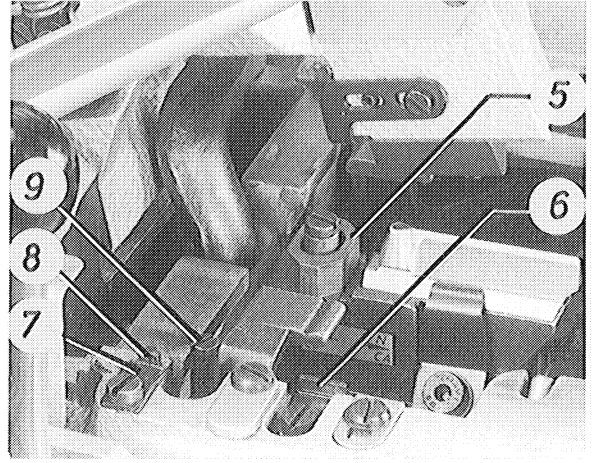
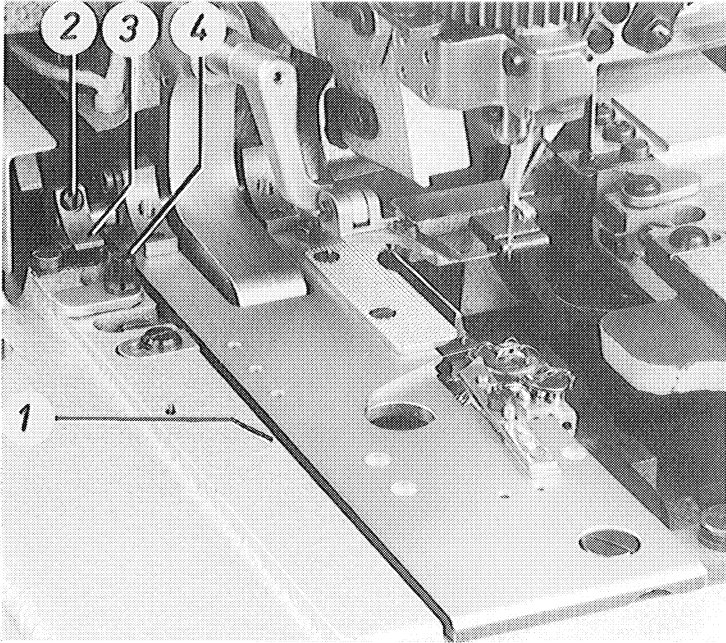



## 18. Clamping plates



Turn off main switch!

### 18.1 Parallel alignment to the fabric rest plate

- Position the left clamping plate.
- Shift the stopper piece 10.
- Loosen screw 4. Push clamping plate to the left, until it rests against edge 1 with its entire length.
- In this position, press screw 4 closely against the clamping plate and tighten.
- If the clamping plate moves back to stopper 6, the distance between plate and edge 1 must be equal on their entire length.
- To adjust the right clamping plate, proceed analogously.

### 18.2 Adjusting the stopper pieces

- Position both clamping plates.
- Turn the hand crank until the rollers under the clamping plates are located on the highest point of spreading block 5 and both clamping plates are thus spread laterally.
- Laterally align the clamping plates on the fabric rest plate such that the distance to the left edge 1 and right edge 2 is equal. Set the stopper pieces 10 and 13 close to the edge.

### 18.3 Adjusting the locking blocks

The locking blocks 3 prevent the clamping plates from slipping out of their spread position during cutting and sewing.

- With closed and spread clamping plates loosen the screws 2.
- Place locking blocks 3 onto shackle 7 and against the spring-mounted lock bolts 8. Tighten screws 2. The locking blocks 3 must, however, not exert pressure on shackle 7.
- If spreading is repeated with closed clamps, the lock bolts 8 must move in front of the locking blocks 3.
- Check whether the locking blocks 3 can move freely across the lock bolts 8, when the clamping plates are opened.

### 18.4 Spreading the clamping plates

Normally a spreading of 1.5 mm is sufficient. This spreading value is required when the distance between the edges of the clamping plates and edges 1 and 14 is 2 mm.

On subclass -114000 a spreading of only 0.2 mm is required for unhindered removal of the clamping plates.

- Adjust the distance by shifting the stoppers 6 and 12.
- The 2-mm-thick gauge 11, order no. 558 1633, is used to make measurements. For greater spreading adjust a greater value. Both clamping plates should perform an equal lateral spreading motion.

### 18.5 Adjusting the upper cloth clamps



Turn off main switch!

- Set the automat at maximum buttonhole width. The maximum buttonhole widths admissible for the different types of sewing equipment can be noted from the tables in section 23.
- To set the needle bar from its zero position to its extreme right position, turn the handwheel in the arrow-indicated direction.
- With closed and spread clamping plates move the upper cloth clamps along the needle using the hand crank.

The distance to all sides should be 0.5 mm. To make adjustments in longitudinal direction loosen screw 15 and to make adjustments in transverse direction loosen Allen screw 16.



## 19. Symmetrical eyelet shape, eyelet centre and equal length of the buttonhole lips

### Note!

Prerequisite for correct adjustments as described in sections 19, 20, 21 and 23 is that the needle bar centre of rotation must be accurately aligned with the looper block centre of rotation.

It is, therefore, advisable to check as described in section 38.1.

The buttonhole eyelet should be circular (symmetrical). Should this not be the case, the motion of the upper control cam starts too soon or too late.

Due to an accurately positioned eyelet centre, the shaft encoder 4 enables equal lengths of the left and right buttonhole lip.

- Turn on main switch.
- Stitch the seam pattern on thin cardboard, using short needle.
- If necessary, loosen screw 1 and turn plate 2 for the control cams accordingly on the control cam drive shaft. Tighten screw 1.

- Enter programme 43 at the switch "Programme" and activate by STOP-push button.
- Turn the hand crank of the automat until the looper block has rotated in the buttonhole eyelet by 90°. See figure.
- In this position the display must show OK.

Should this not be the case, loosen the two screws 3 and slowly turn the shaft encoder until OK appears.

**Attention!** The adjustment range only has a "width" of 0.9°. Tighten screws 3.

- Stitch the seam pattern again and check for equal lengths. In the case of differing lengths of the buttonhole lips, slightly reset the shaft encoder 4. (It may be that OK is displayed, although the looper block is slightly outside its 90°-position).

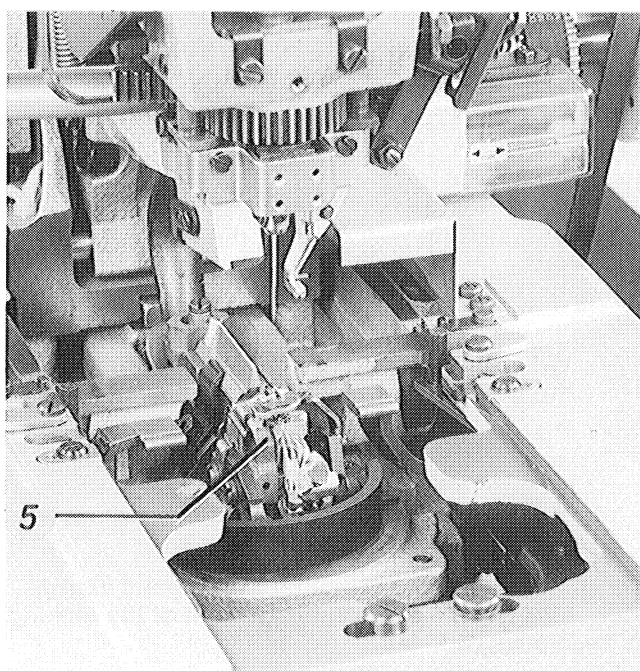
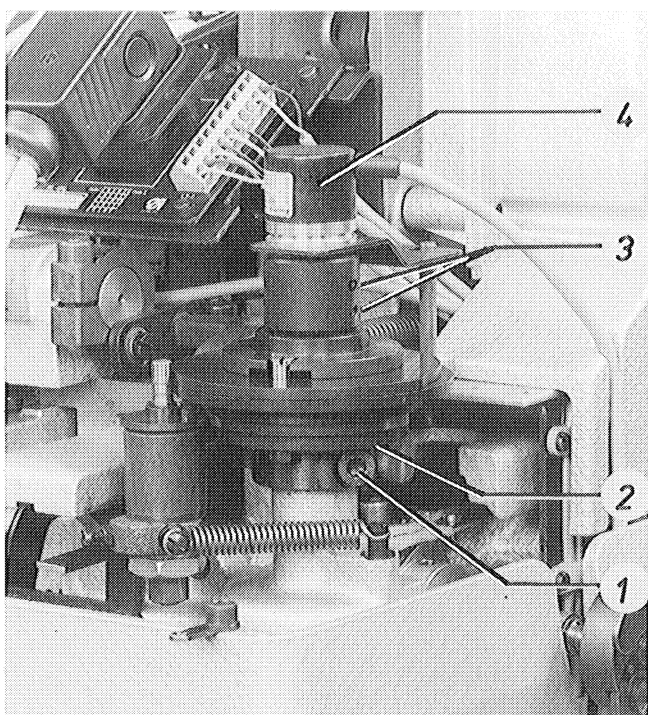



## 20. Needle zero position

The needle zero position is on the left that is, the oscillation of the needle bar is unilateral and is performed from the left to the right during sewing of the right buttonhole lip.

When changing over from the smallest to a greater buttonhole width, the position of the inner punctures must not change, but only that of the outer punctures.

- Turn on main switch.
- Stitch the seam pattern with minimum and maximum buttonhole width in thin cardboard using a short needle. See figure.

- Should the inner punctures not be aligned accurately at minimum and maximum buttonhole width, loosen nuts 1 and 3.

**Attention! Nut 3 has a lefthand thread.**

- Turn connecting rod 2 to obtain an accurate alignment of the inner punctures.
- Tighten nuts 1 and 3.

**Attention!** Depending on E-Nr. the position of screw 4 limits the minimum and maximum buttonhole width. Its position must not be changed. See table in section 23 for maximum buttonhole width.

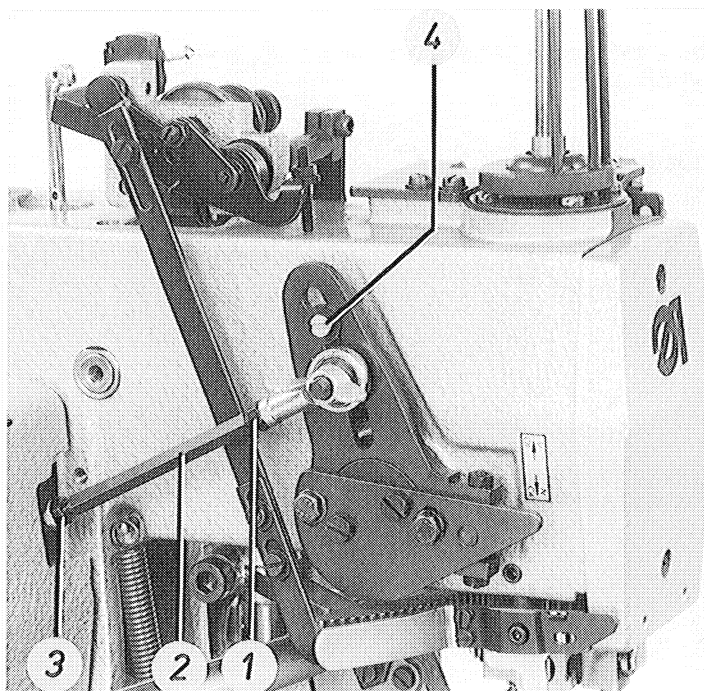
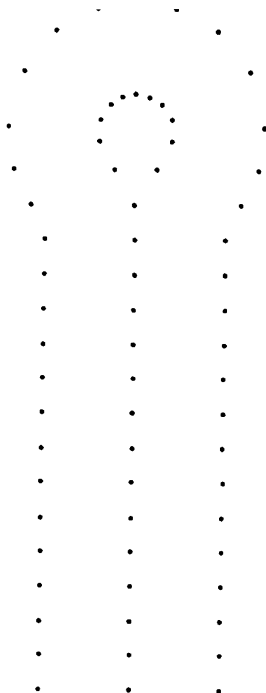



## 21. Cutting space between the two seam rows

On automats that cut after sewing, a small cutting space for the knife cut must be between the two seam rows. See figure a.

The cutting space should be approx. 0.4 mm. Special materials, such as thick fabrics, fine leather, etc. may require a wider cutting space.

On automats that cut before sewing, the inner needle punctures must be aligned accurately. See figure b.

On subclass -114000, the size of the stitched eyelets from 2-5 mm is determined by changing the cutting space.

See table in section 23 for specifications.

**Attention!** The needle zero position must have been adjusted before as described in section 20.

- Turn on main switch.
- Stitch the seam pattern on thin cardboard using a short needle.
- Loosen screws 4.

- On automats that only **cut before sewing** adjust the accurate alignment of the inner needle punctures using set screws 1 and 3. See figure b. Lock the set screws with a nut so as to eliminate any play.
- On automats that only **cut after sewing** the inner needle punctures are set apart for a cutting space of eg 0.4 mm using set screws 1 and 3. See figure a. Lock set screws with a nut so as to eliminate any play.
- On automats that **cut before and after sewing**, first the inner needle punctures are aligned using set screws 1 and 3.
- Lock the upper set screw 1 with a nut.
- Turn back the lower set screw 3 by the corresponding value, press down lever 2 and tighten screws 4.
- When the correct cutting space has been obtained as can be seen by a test on cardboard, lock the lower set screw 3 with a nut.
- After loosening screws 4, lever 2 can be pressed up completely for cut before, and down completely for cut after.

Nach dem Nähen schneidend  
Cutting after sewing

Vor dem Nähen schneidend  
Cutting before sewing



Abb. a  
Fig. a



Abb. b  
Fig. b



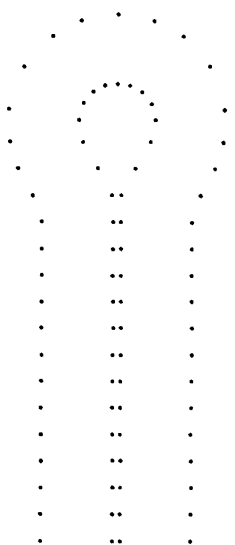

## 22. Anvil body and cutting lever

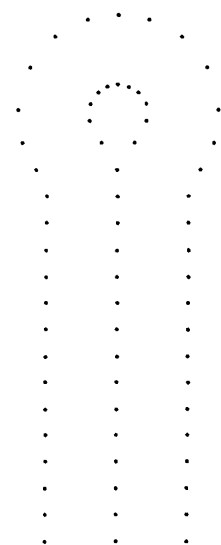
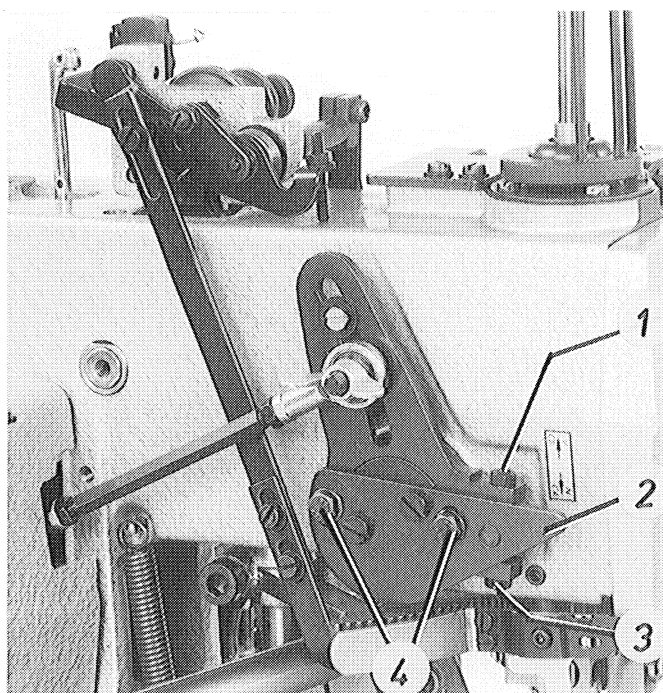

**Turn off main switch!**

On automats for cut after sewing, knife 1 should cut accurately between the seam rows and at the centre of the eyelet. See figure a.

On automats for cut before sewing, an upper control cam for smaller eyelets is used. Here, the knife should cut accurately on the aligned inner punctures and around the eyelet.

As shown in figures a and b, the versions cut before and after result in the difference  $x$ , by which knife 1 must be shifted within the stoppers 2 and 3, when changing the automat over.

**Note!** Automats for cut before are equipped with the rear stopper 2 only and automats for cut after with the front stopper 3 only.

Align the cutting lever such that the knife hits at the centre of the cutting block (see impression of the knife).

Insert the cutting blocks 5 such that they rest against stopper 4.

Prerequisite for the adjustment is the correct needle zero position as described in section 20.

### Anvil body

Set stopper 3 approx. at the centre of its elongated hole and shift the knife completely to the front.

Nach dem Nähen schneidend      Vor dem Nähen schneidend  
Cutting after sewing              Cutting before sewing



Abb. a  
Fig. a

Abb. b  
Fig. b





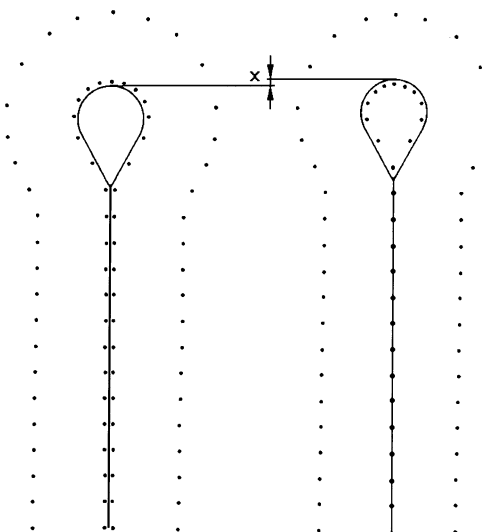
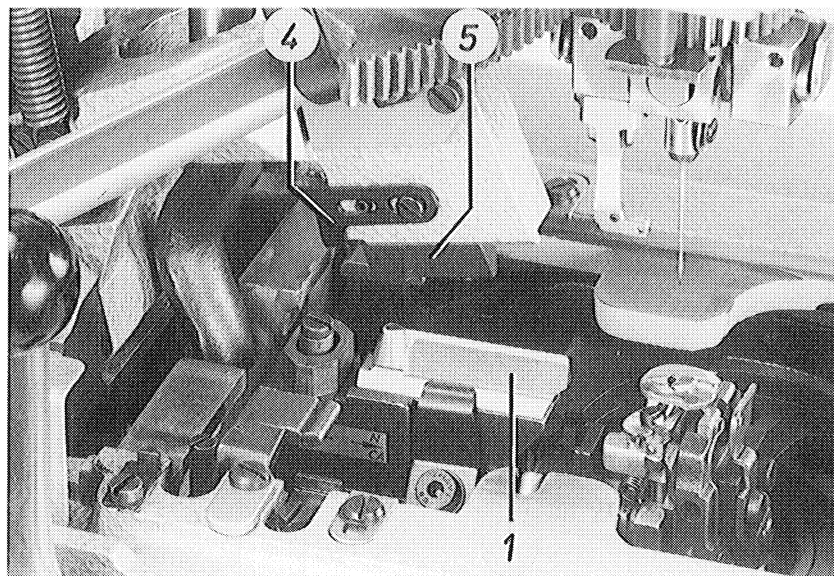
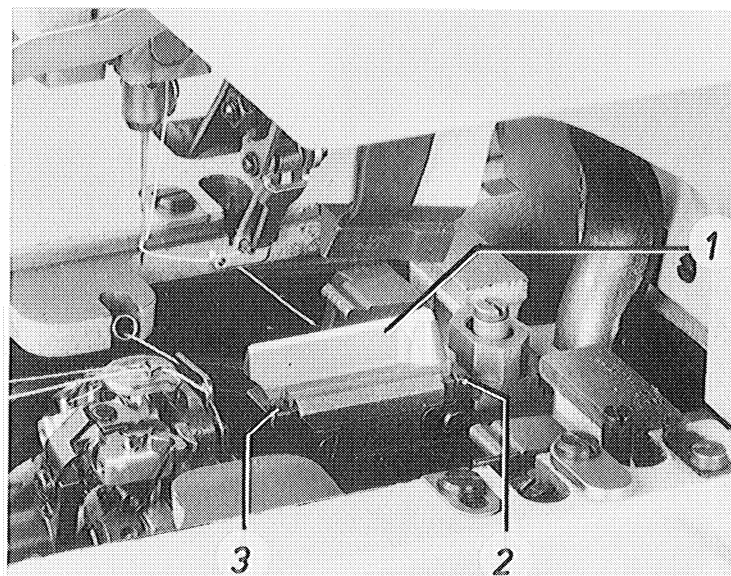
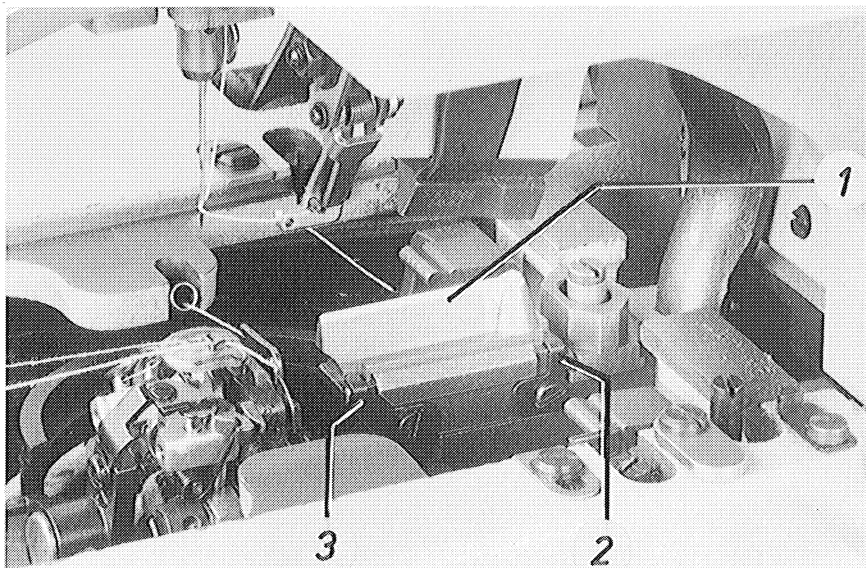
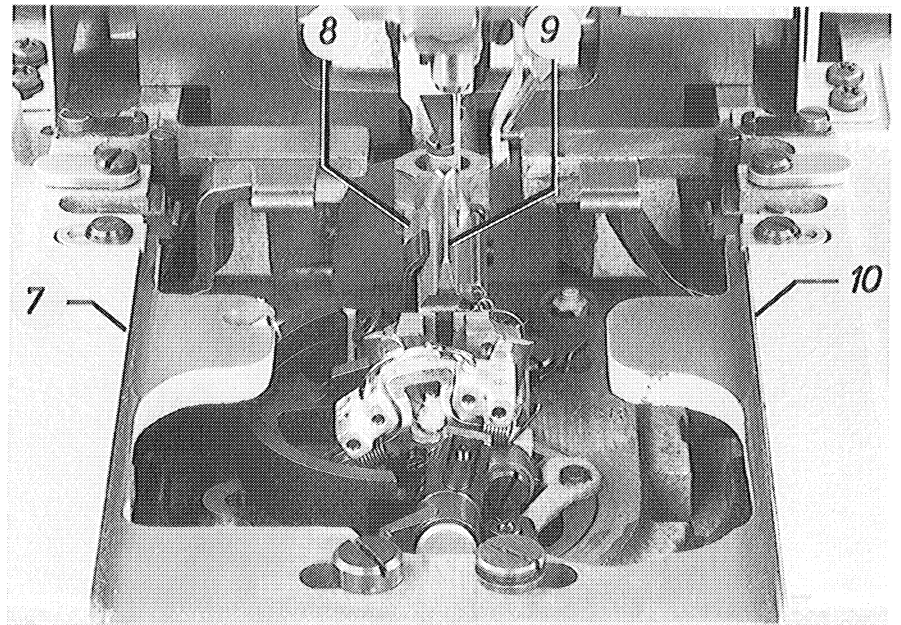
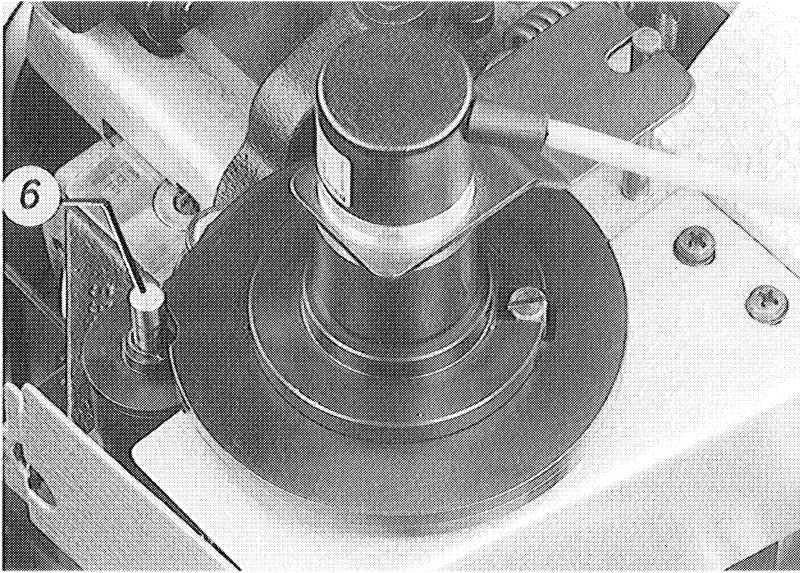

- Turn the automat out of its end position using the hand crank, until roller bolt 6 has rolled off the cam of the bottom plate and rests against the upper control cams.
- Slightly loosen the screws of the anvil body 8.
- Adjust an equal distance between knife blade 9 and edges 7 and 10 of the fabric rest plate using a slide gauge.
- Check the knife, when cut after sewing is adjusted. Except for automats that only cut before sewing, eg subclass -114000.
- Turn on main switch.
- Push the stopper 3 until it rests against the knife and tighten.  
Tighten the screws of anvil body 8 securely.
- Slip on the upper control cam for cut before with a smaller eyelet. Also, insert the cutting block for cut before.
- Push the knife to the rear by the amount x (approx. 1 mm).
- Stitch again a seam pattern on cardboard and, if necessary, correct the position of the knife in longitudinal direction.
- Push stopper 2 until it stops and tighten.



Warning of personal injury when working on anvil body and cutting lever! With turned on main switch keep hands clear of the knife area.

- Enter programme 02 at the switch "Programme" and activate by STOP-push button. Switch to ---> N using -key  $\Sigma$  "setting counter".

Re-activate P01.

- Stitch seam pattern on thin cardboard using a short needle and check the position of the knife cut.
- Align the anvil body appropriately and set the knife accordingly.

### Cutting lever

- The knife should hit at the centre of the cutting block (see knife impression).
- To enable this, further screw the bearing screws 11 in or out and shift the cutting lever laterally.
- When the nuts 12 are locked, the cutting lever must move up and down without play, but still easily.
- Set stopper 4 such that the knife impression has the given cut length on the cutting block.

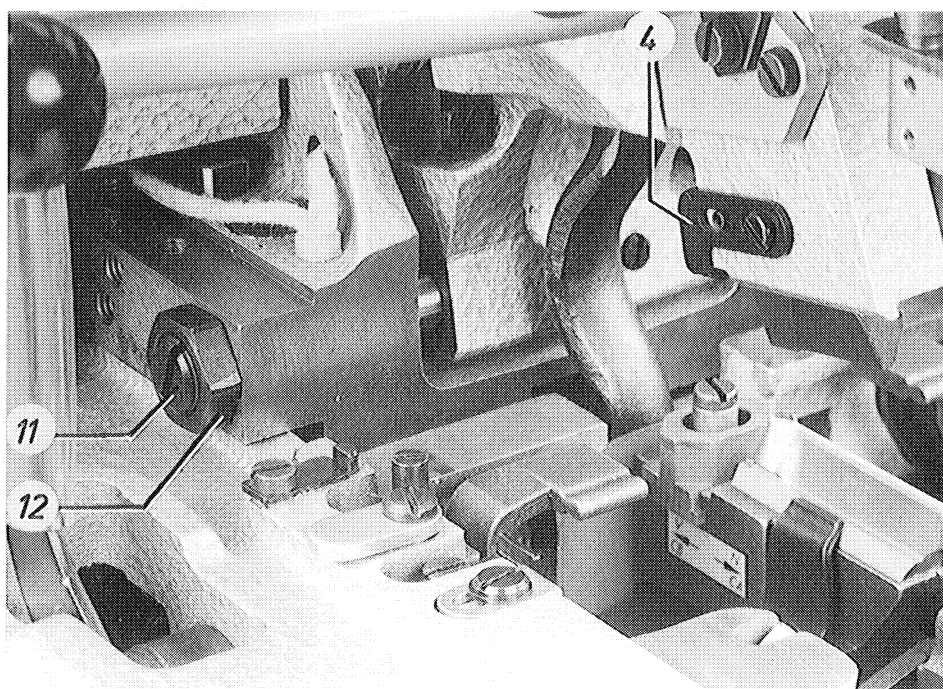



## 23. Looper

### 23.1 Adjusting the looper height



**Turn off main switch!**

Before adjusting the loop stroke and needle bar height, check whether the loopers are located at the correct height.

To check the looper height, use gauge 1, order no. 557 604.

- Remove throat plate 4, spreader stoppers 2 and spreader 3 from the spreader support.
- Raise the needle bar to its up position.
- When the loopers are installed in the looper support until they stop, place the gauge on the looper support as shown in the figure.

- The point of the left looper should be located under edge a of the gauge and the point of the right looper under edge b. Hole c of the gauge should point to the right.
- In this position of the gauge the looper points should just touch the gauge.
- Slightly bend the loopers to obtain the looper height.

Especially in the case of needle breakage, the looper height should be checked.

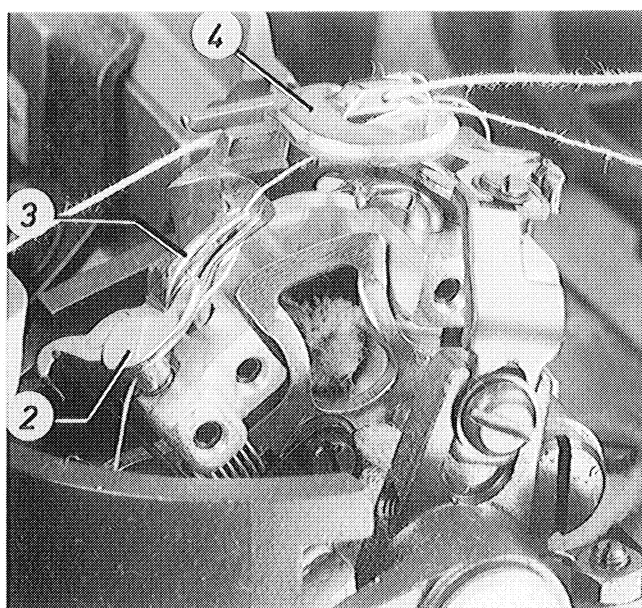



## 23.2 Adjusting the loop stroke



**Turn off main switch!**

The loop stroke is the path that the needle bar has to travel from its bottom position to the point, where the left or right looper point is at the centre of the needle.

To adjust the loop stroke, set the maximum buttonhole width. The maximum buttonhole widths and loop stroke measurements laid down for the different types of sewing equipment (E-Nr.) may be found in the following table.

- Set the maximum buttonhole width at frame 5.

- Move the needle bar to its lower dead point. In this position measure the depth between the upper edge 7 and bushing 6 parallel to the needle bar using a slide gauge.
- To the measurement obtained thus add the loop stroke measurement on the slide gauge, place the slide gauge again parallel to the needle bar on bushing 6 and turn the handwheel in the arrow-indicated direction until the needle bar rises by the amount on the slide gauge.
- When the needle has entered on the left, the left looper point should be at the centre of the needle, and when the needle has entered on the right, the right looper point should be at the centre of the needle. See figures a and b.
- Turn the looper cam to reach this position.



Abb. a  
Fig. a



Abb. b  
Fig. b



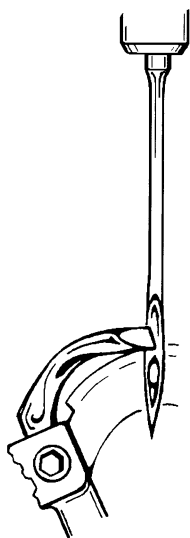



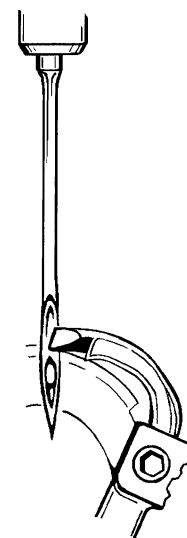
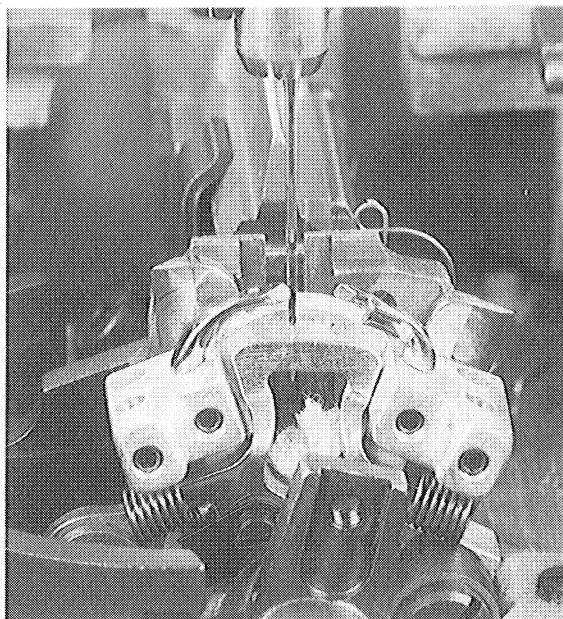
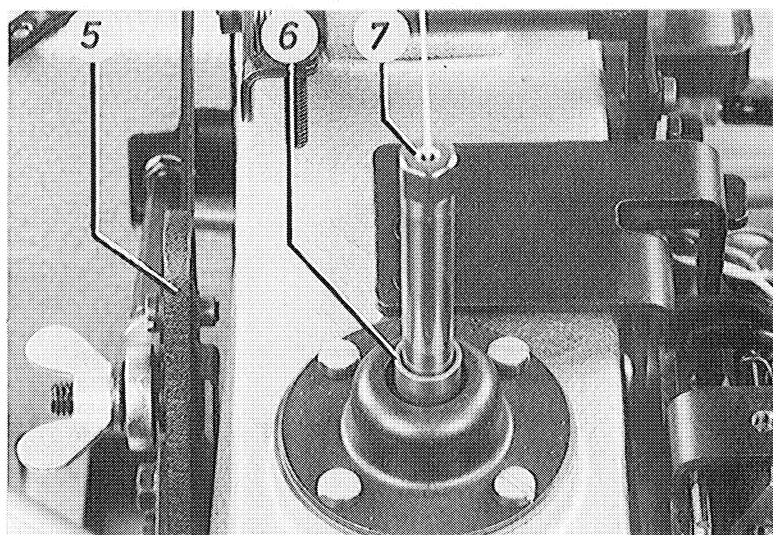
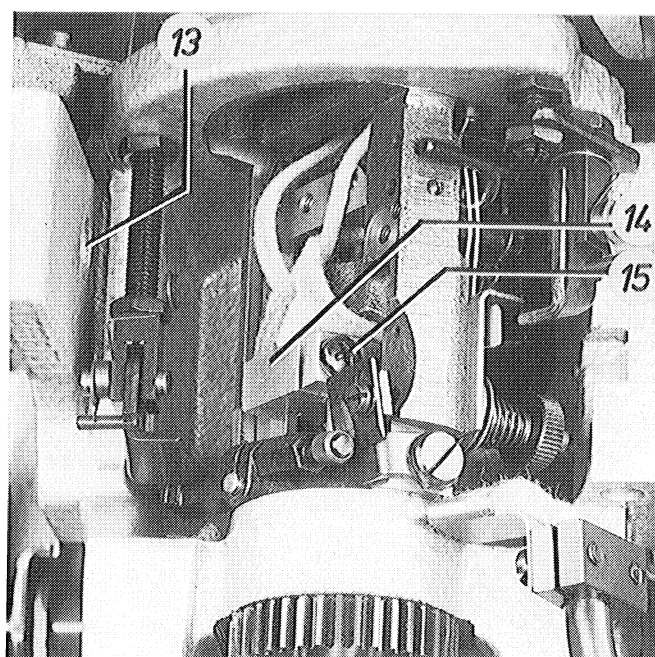
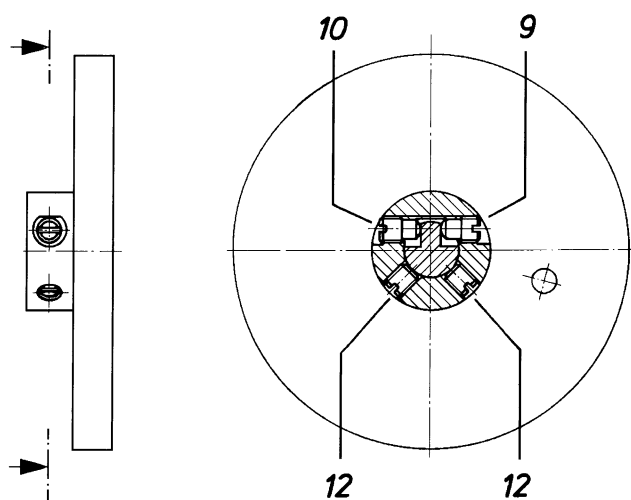
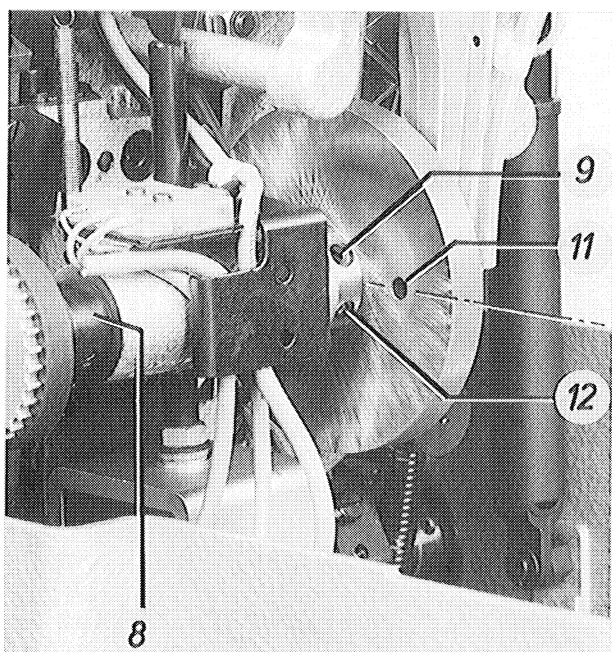

- The basic adjustment is as follows: When the needle bar is in its highest position and above its left needle puncture, hole 11 of the looper cam should be on a horizontal line, as shown in the figure.
- To make an accurate adjustment, first loosen screw 15 that is accessible behind the looper block and shift clamping piece 14 to adjust the looper support such that right and left looper point are located at an equal distance to the needle.  
In basic position of the looper block, screw 15 is accessible through hole 13.
- Set the looper points at the centre of the needle at the left looper when the needle enters on the left. Set screws 9 and 10 are only accessible in this position.
- Loosen lock screws 12. If eg the left looper point is located at the centre of the needle, turn front set screw 9 out and rear set screw 10 in.
- Measure at the left and right needle puncture, and, if the position is correct, tighten lock screws 12.
- If necessary, set the shaft of the looper cam tight to adjustment ring 8.









Equipment table and function features

578	Material	Buttonhole shape				Buttonhole cut		Trimmer for short threads	Buttonhole width		Cutting space	Loop stroke
						before	after		min. mm	max. mm		
-112211	Loose, coarsely woven fabrics light- to heavy weight	E731 / 16					---> N	needle thread looper thread	4,5	5,8	0,4	2,7
-112221	"	E731 / 18					---> N	"	4,5	5,8	0,4	2,7
-112231	"	E731 / 22					---> N	"	4,5	5,8	0,4	2,7
-112241	"	E731 / 24					---> N	"	4,5	5,8	0,4	2,7
-112251	"	E731 / 28					---> N	"	4,5	5,8	0,4	2,7
-112261	"	E731 / 26					---> N	"	4,5	5,8	0,4	2,7
-112271	"	E731 / 20					---> N	"	4,5	5,8	0,4	2,7
-113211	"			E831 / 16			---> N	needle thread looper thread	4,5	5,8	0,4	2,7
-113221	"			E831 / 18			---> N	"	4,5	5,8	0,4	2,7
-113231	"			E831 / 22	E808 / 22		---> N	"	4,5	5,8	0,4	2,7
-113241	"			E831 / 24			---> N	"	4,5	5,8	0,4	2,7
-113251	"			E831 / 28			---> N	"	4,5	5,8	0,4	2,7
-113261	"			E831 / 26			---> N	"	4,5	5,8	0,4	2,7
-113271	"			E(831 / 20			---> N	"	4,5	5,8	0,4	2,7





## Equipment table and function features

578 	Material	Buttonhole shape					Buttonhole cut		Trimmer for short threads for	Buttonhole width		Cutting space	Loop stroke	
							before	after		min. mm	max. mm			mm
-114181	Fabrics of different quality and thickness						E901/ Ø2-5	V <---		needle thread	-	-	2 - 5	2,7
-121301	Buttonholes with handwork appearance	E209/ 10-38	E210/ 6-38						---> N	needle thread, looper thread and long gimp	4,1	5,2	0,4	3,0
	High-quality garments of differing thickness	E212/ 10-38		E214/ 12-34				V <---	---> N	"	5,0	7,0	- / 0,4	2,7
-131391	Loose, coarsely woven fabrics		E306/ 6-38	E307/ 12-34					---> N	needle thread	4,5	5,8	0,4	2,7
	Buttonholes with handwork appearance in garments	E309/ 18+24							---> N	"	4,1	5,2	0,4	3,0
	Narrow buttonholes in stretch material (eg knit fabrics) with round or flat gimp				E311/ 6-34				---> N	"	4,1	5,2	0,4	3,2
	Fabrics of different quality and thickness	E312/ 10-38		E314/ 12-34				V <---	---> N	"	5,0	7,0	- / 0,4	2,7
	Garment leather	E327/ 10-38						V <---	---> N	"	5,0	7,0	- / 0,6	3,2
-141291	Jeans waistbands, stepped cloth clamps			E328/ 16-20					---> N	"	4,5	5,8	0,4	3,0
	Fine, closely woven fabrics, eg poplin	E334/ 10-38						V <---		"	6,0	7,0	-	2,7
	Loose, coarsely woven fabrics			E407/ L1-L4					---> N	needle thread, looper thread, gimp	4,5	5,8	0,4	2,7
-141291	Buttonholes in stretch material, eg knitted fabrics				E411/ L1-L2				---> N	"	4,5	5,8	0,4	3,0
	Waistbands in jeans, and suchlike			E417/ L1-L2					---> N	"	4,5	5,8	0,4	3,0
	Loose, coarsely woven fabrics, raised stitches			E431/ L1-L4					---> N	"	4,5	5,8	0,4	2,7



### 23.3 Needle bar height



**Turn off main switch!**

The needle bar height is 2.5 mm.

Exception: 2 mm on subclass -114000.

Determine the lower dead point of the needle bar using the depth gauge on a slide gauge, add the loop stroke measurement according to the table as well as the measurement of the needle bar height, eg

lower needle bar dead point	11.1 mm
+ loop stroke	2.7 mm
+ needle bar height	2.5 mm
	<hr/>
	16.3 mm

When the needle has risen by this amount from its lower dead point, three quarters of the needle's eye should be visible below the bottom edge of the left looper, as shown in the figure.

- Set the maximum buttonhole width.
- Loosen adjustment rings 2 and 4. Adjust the needle bar height accordingly.
- To assure smooth rotation of the needle bar during sewing of the eyelet, set the two adjustment rings and crosshead 3 so tight that only a drop of oil can pass.

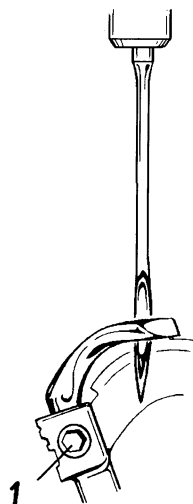

### 23.4 Looper - needle clearance



**Turn off main switch!**

The clearance between looper points and needle should be 0.1 mm.

- Loosen screws 1 and adjust the looper accordingly.
- The looper clearance should be equal during the entire looper block rotation. If this is not the case, correct the needle bar centre of rotation as described in section 38.1.

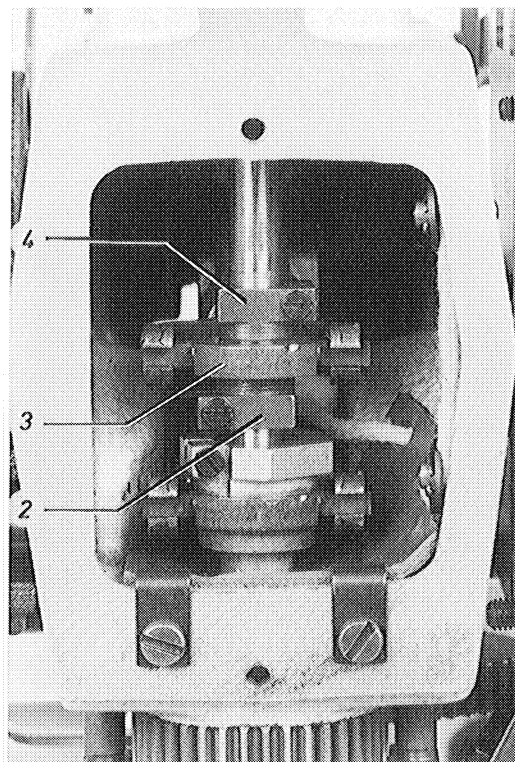



## 24. Needle guard



**Turn off main switch!**

The needle should rest against the needle guard 1, until the looper points reach the needle. If the looper points are at the centre of the needle, the looper clearance described in section 23.4 must be perceptible.

- The needle guard 1 was adjusted at the factory and normally does not need to be re-adjusted.
- If necessary for other needle thicknesses, bend the needle guard accordingly.

## 25. Spreader



**Turn off main switch!**

The clearance between fork spreader 3 and left looper must correspond to the looper thread thickness.

The right spreader 5 should move across the top surface of the right spreader as close as possible, but without touching it.

If necessary, bend the spreader. The spreaders must move smoothly within the looper support.

The spring loaded spreaders are kept in their end position by the stoppers 2. The fork of the left spreader should be located accurately above the thread hole of the left spreader and the point of the right spreader should be right above the point of the right looper.

The motion of the right and left spreader must be regular that is, just before the lower needle bar dead point at a left needle puncture the left spreader, and at a right needle puncture the right spreader must rest against the corresponding spreader stopper.

- Set the maximum buttonhole width.
- Loosen screw 7 slightly.
- Shift clamping piece 6 on the spreader drive spindle to shift the spreader actuation plate 4 accordingly.

**Note!** In the case of sewing equipment (E-Nr.) with small buttonhole widths the closing motion of the spreaders is completed a little later.

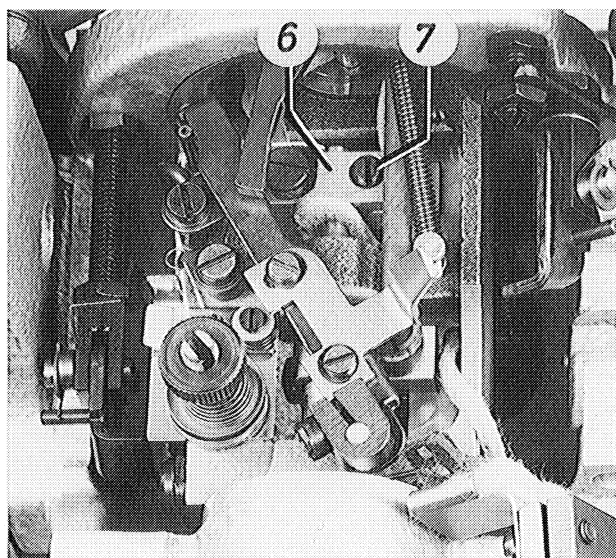
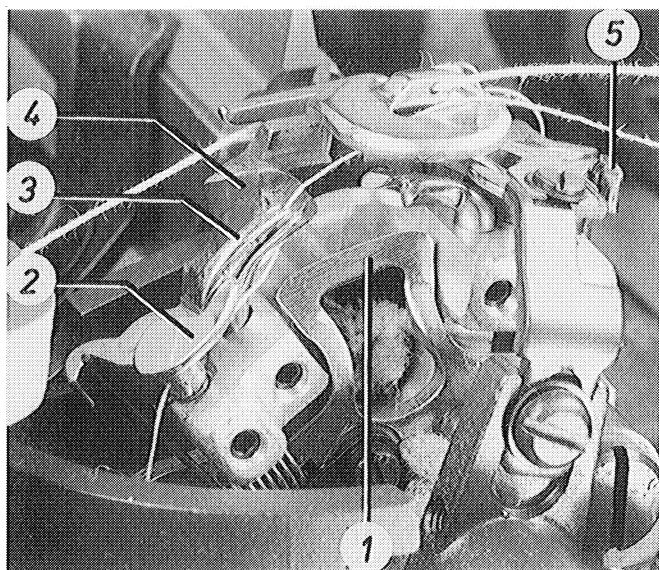



## 26. Throat plate



**Turn off main switch!**

The needle should enter the needle hole of the throat plate on one side at the edge 2. The clearance between needle and edge 2 should be approx. 0.5 mm.

The throat plate must be positioned level with the clamping plates to prevent the material from being pressed down too much by the penetrating needle.

In the throat plate guide groove 1 of the looper block is a stop screw for adjusting the height, so that the adjustment is preserved, when a throat plate is installed again.



To prevent the throat plate from breaking, it must never hit anywhere during the sewing cycle.

Check this by turning the crank. Especially in the following areas there must still be a small clearance to the throat plate:

- Under the scissors 4 for the looper and gimp thread trimmer.
- Under the lower cloth clamps 5.
- The needle thread knife 3 must move below the throat plate as close as possible, but without touching it.

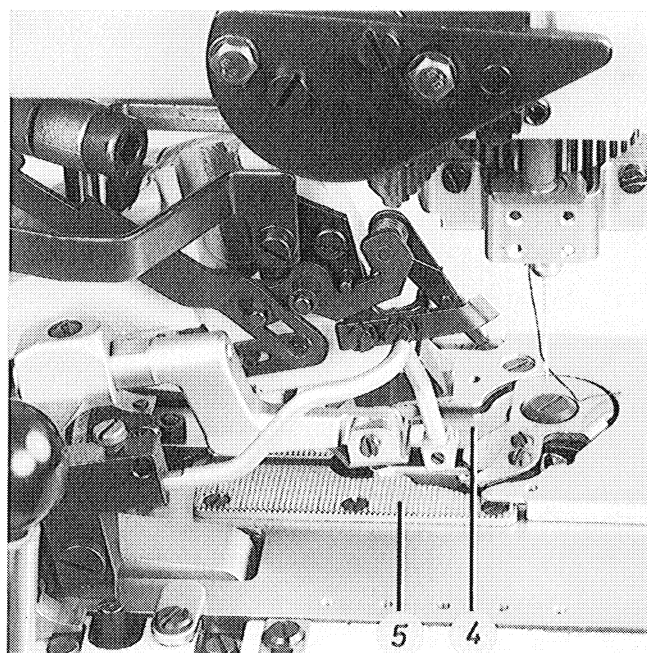
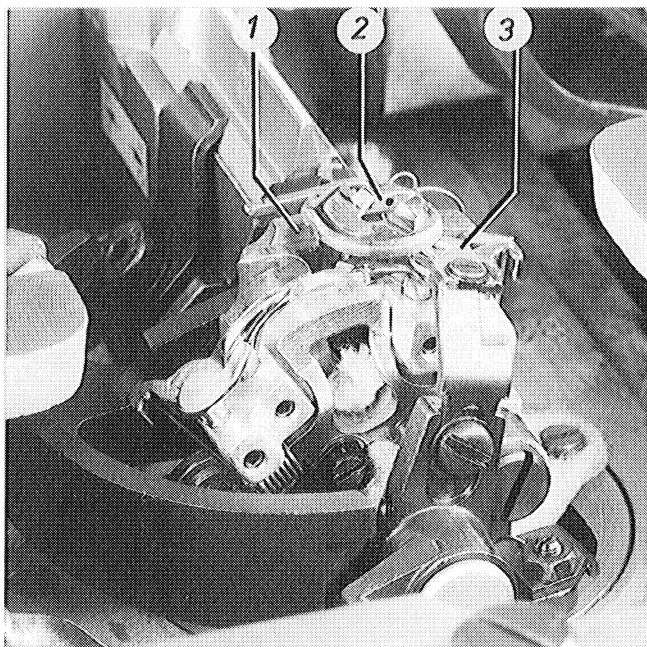

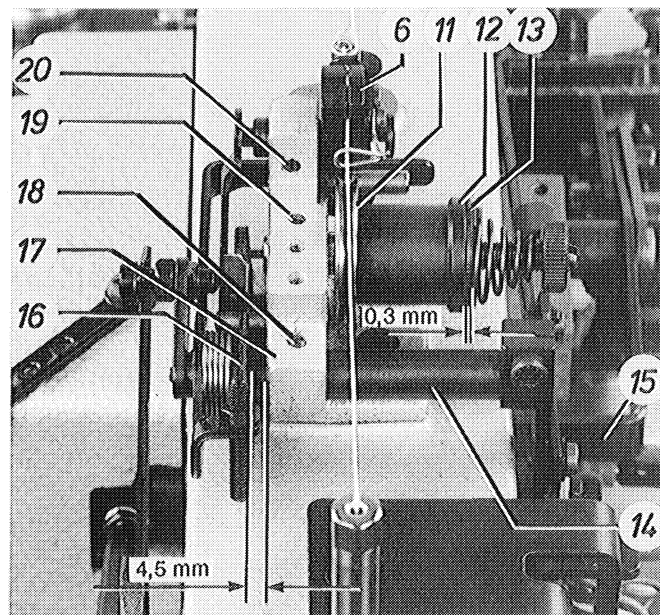
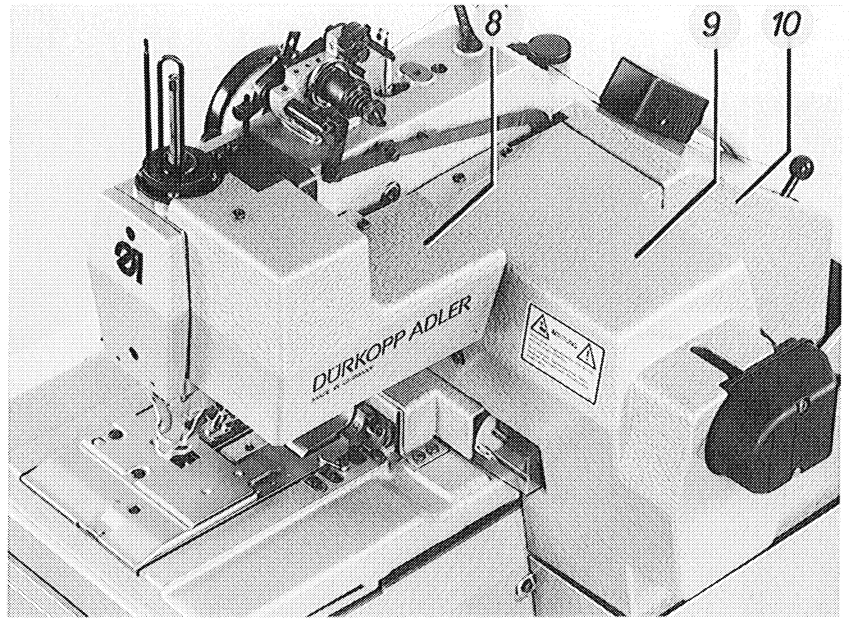
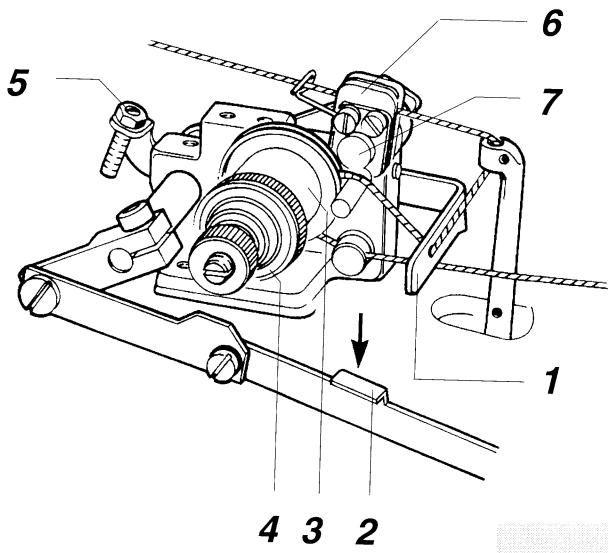



## 27. Needle thread puller and tension release



**Turn off main switch!**

The needle thread puller 1 assures a thread tail that is always of equal length and thus a secure stitch formation at the seam beginning.

The thread clamp 6 releases the pulled forward needle thread only just before the seam beginning.

For pulling forward the needle thread by hand at the end position of the automat, press the release button 7, or swivel the rods 2 down completely.

The needle thread tension is designed as a double tension.

It incorporates the actual main tension 4 and the secondary tension 3, which tensions the needle thread for the trimming process under the throat plate.

The secondary tension 3 is not opened after the seam end.

Its adjusted tension value influences the length of the needle thread tail at the seam beginning.

The main tension should open after the seam end, but before the needle thread is trimmed.

- Remove covers 9 and 10, if exists also cover 8.
- Turn on main switch.
- Enter programme 50 at the switch "Programme" and activate by STOP-push button.
- Press down pedal and move the automat out of its end position up to the 1st stop (seam beginning).

- Loosen screw 20.  
Adjust a distance of 1 mm between the clamping jaws of the thread clamp 6. To do this, move the thread clamp in or out as needed.  
Tighten screw 20.
- Loosen screw 19.  
Align the tension disks 11 with the thread clamp to assure a straight thread intake.  
Tighten screw 19.
- Loosen screw 18.  
Set a distance of 4.5 mm between block 17 and washer 16. Shift the bearing bushing 14 accordingly.  
Tighten screw 18.
- Move the automat into its end position by tipping the pedal. Loosen screws 23 of the curved sheet.  
Lower the lever 15 until the distance between Reglet washer 13 and bushing 12 is 0.3 mm that is, only the secondary tension acts on the tension disks.  
Let the curved sheet 24 in this position rest on roller 22.  
Tighten screws 23.
- Press down pedal and run the automat to the 1st stop (seam beginning).  
Loosen screw 26 and adjust lever 25 such that the distance between edge 21 of the curved sheet and roller 22 is approx. 1 mm.  
Tighten screw 26.
- Thread the needle thread as shown.  
In the seam beginning position of the automat turn the stop screw 5 such that the needle thread puller 1 is located accurately in direction of thread pulling (dotted line) between thread take-up lever and tension disks.

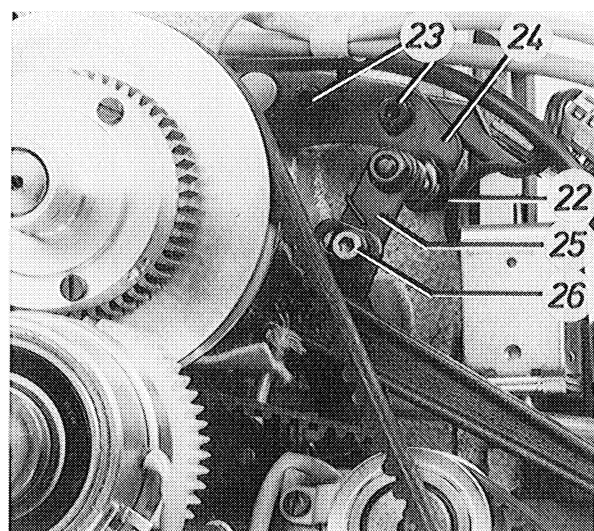
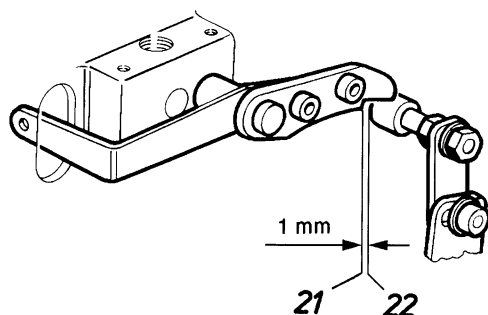

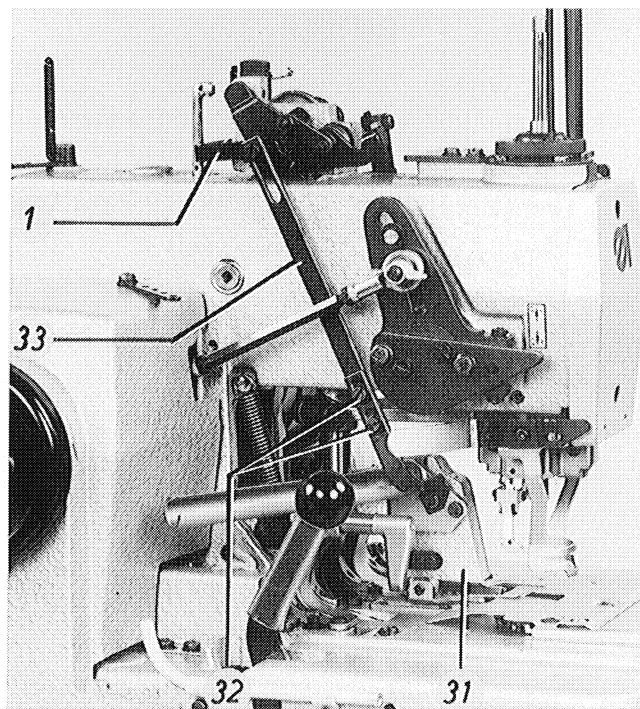
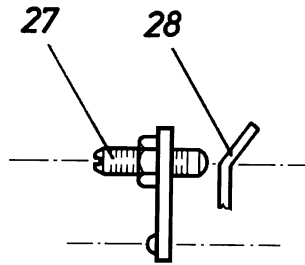
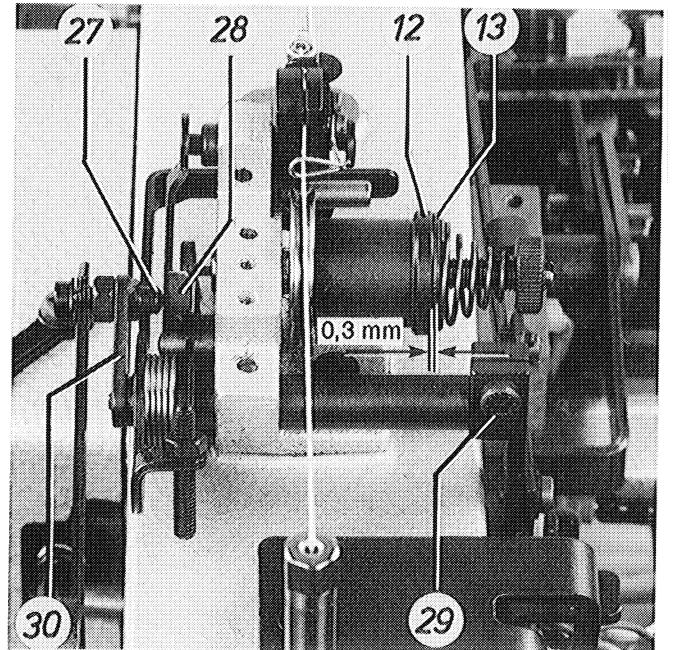
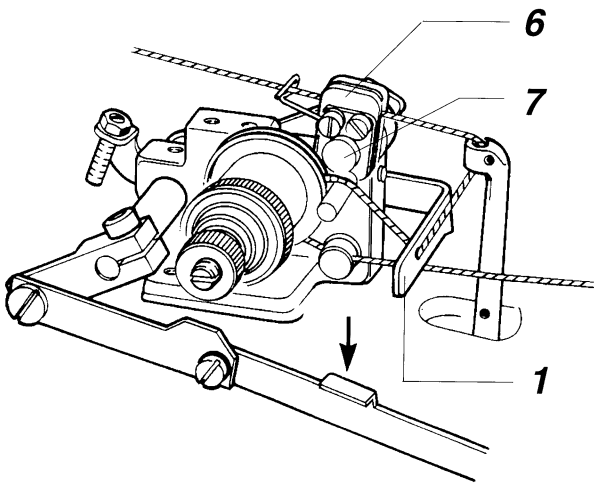



- The needle thread puller 1 should unwind the initial thread for the next sewing cycle from the cone and should not pull the thread from the needle thread tension.

It is, therefore, important to observe the sequence of functions: first thread clamping and then thread pulling.

Turn the hand crank slowly, until the downward motion of the needle thread puller becomes visible.

At this moment the pressure screw should be located at the beginning of the straight surface of the actuating lever 28. See sketch.

It is advisable to loosen the pressure screw 27 a few turns.

Loosen screw 29.

Swivel the lever 30 with pressure screw such that it is located as shown in the sketch. Tighten screw 29.

Tighten screw 27 so that the needle thread is clamped lightly.

Excessive pressure makes actuation of the release button 7 difficult.

Thread clamp 6 must not be pressed together completely, spring action must still be possible. This is perceptible, when the thread clamp still opens when button 7 is pressed.

- With inserted cutting block and cutting knife, turn the hand crank until the cutting lever 31 is in its bottom position.

- After loosening the screws 32 pull the thread puller to its bottom position by shifting the rods 33.

There should be a safety distance to the machine arm.

Tighten screws 32.

Should the thread tail at the seam beginning be too long after sewing a test seam, the thread puller can be adjusted to pull less thread by rods 33.

#### Note!

When equipped with an electro-pneumatic needle thread catcher, the thread tail may be too long at the seam beginning, especially in the case of short buttonhole lengths.

Set the needle thread puller 1 parallel to the machine arm.

- For the thread trimming action loosen the main tension by magnet s11. Enter programme 64 at the switch "Programme" and activate by STOP-push button. For the magnet s11 enter 11 at the switch "Programme".

Actuate the magnet by the -key  $\Sigma$  "setting the counter".

- Loosen nuts 34. When the automat is in its end position, and the magnet s11 is actuated, adjust a distance of 0.3 mm between Reglet washer 13 and bushing 12 by shifting lever 35 accordingly. Tighten nuts 34.

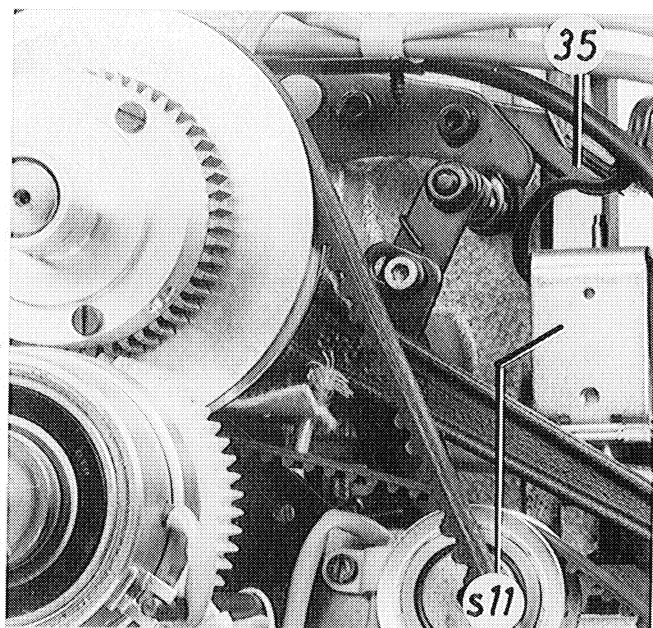
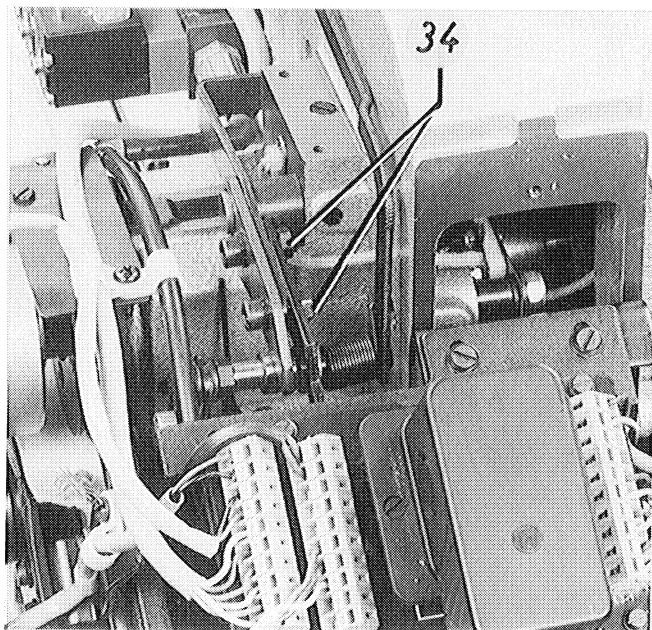

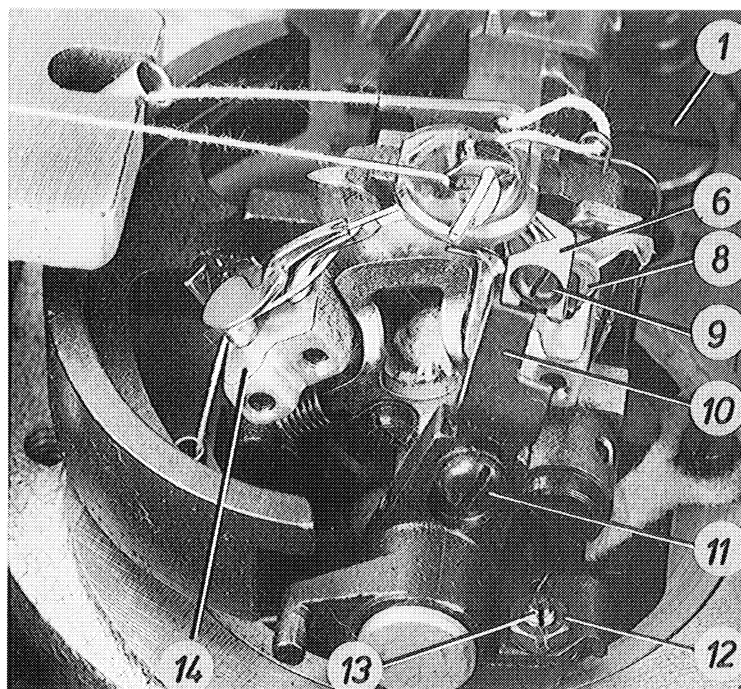
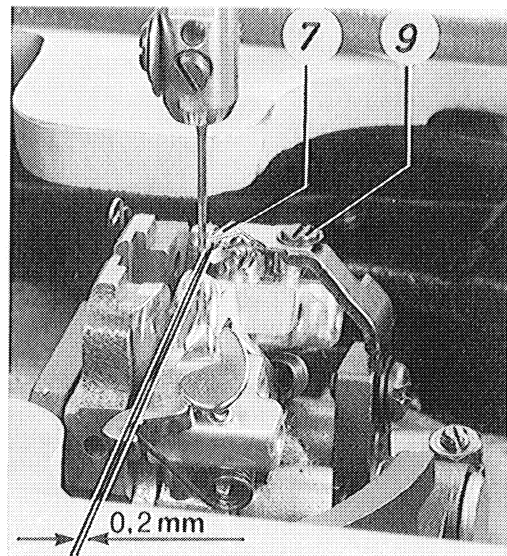
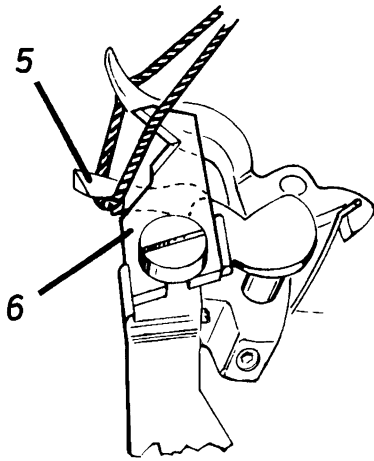
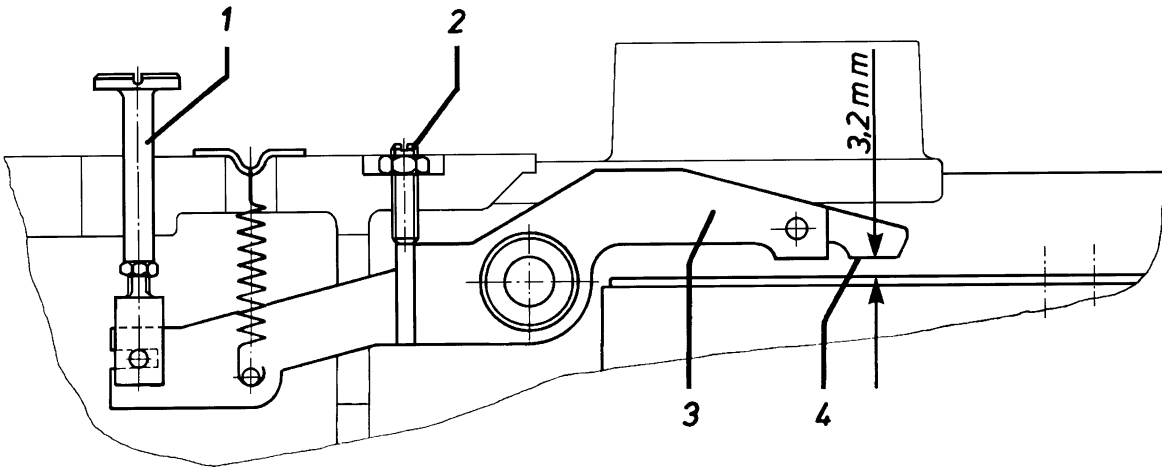



## 28. Needle thread trimmer

**Note!** The adjustment of the needle thread catcher is the same on all subclasses. The figures show subclass -121000.

### 28.1 Control lever for the needle thread trimmer

The control lever 3 is in the machine housing and actuates the needle thread trimmer via feed rod 1.

The height of the control lever with respect to the main control cam is secured by stop screw 2 sealed with yellow lacquer.

Edge 4 of the control lever must be adjusted to the main control cam according to the measurements specified in the figure.

The adjustment can only be made with removed machine arm. Therefore, screw 2 was adjusted at the factory and sealed yellow. It should normally not be adjusted.

### 28.2 Needle thread knife



**Turn off main switch!**

At the seam end the trimming motion of the needle thread knife is actuated by magnet s12. The precise cutting timing is determined in the control.

The needle thread knife 6 should cut the needle thread loop taken up by the right looper 5 in front of the looper.

This is possible when the clearance between the needle thread knife and the needle in its bottom position on the right is approx. 0.2 mm.

If the needle thread loop is cut on both sides, the thread tail is too short, which results in skipped stitches at the seam beginning.

Set the height of the needle thread knife 6 such that it can still move freely and unhindered below the throat plate underside.

When the looper support 14 has moved to its extreme left position, the spreader stopper 8 must not hit the knife support 10 which is in its right end position.

With maximum buttonhole width, the needle entering on the right must pass the needle thread knife at a secure distance.

– Loosen screw 9.  
Adjust a clearance of approx. 0.2 mm between knife point 7 and the needle at down position by shifting the needle thread knife 4.  
Tighten screw 9.

– Swivel the knife holder 10 by hand and check for smooth moving.

– Loosen screw 11.  
Position the knife holder 10 such that the needle thread knife 6 can move as close as possible, but unhindered under the throat plate.  
Tighten screw 11.

– Loosen lock nut 12.  
Turn set screw 13 to move the knife holder to the right until it has a clearance of 0.3 mm to the spreader stop 8.  
Tighten lock nut 12.

#### **Note!**

This adjustment is only made on subclasses -114000, -121000 and -131000.

On subclasses -112000, -113000 and -141000 adjust the set screw 12 as described in section 29.

– With maximum buttonhole width and needle entry on the right, check the clearance between needle and needle thread knife.



## 28.3 Feed rod for the needle thread knife



**Turn off main switch!**

If lever 3 is located under feed rod 1, which is in its upper position (rest position), the clearance between feed rod 1 and lever 3 should be 1 mm.

- Turn the hand crank until the looper block has rotated by approx. 45° and lock nut 6 becomes accessible.
- Swing up the head of the automat.

- Loosen lock nut 6. For safety reasons, first raise feed rod 1 by turning it to the left.
- Turn hand crank further until the looper block has rotated by 180 and lever 3 is located under feed rod 1. Turn the feed rod 1 to the right until the clearance to the lever 3 is 1 mm.
- Turn the hand crank, until lock nut 6 is accessible and can be locked.

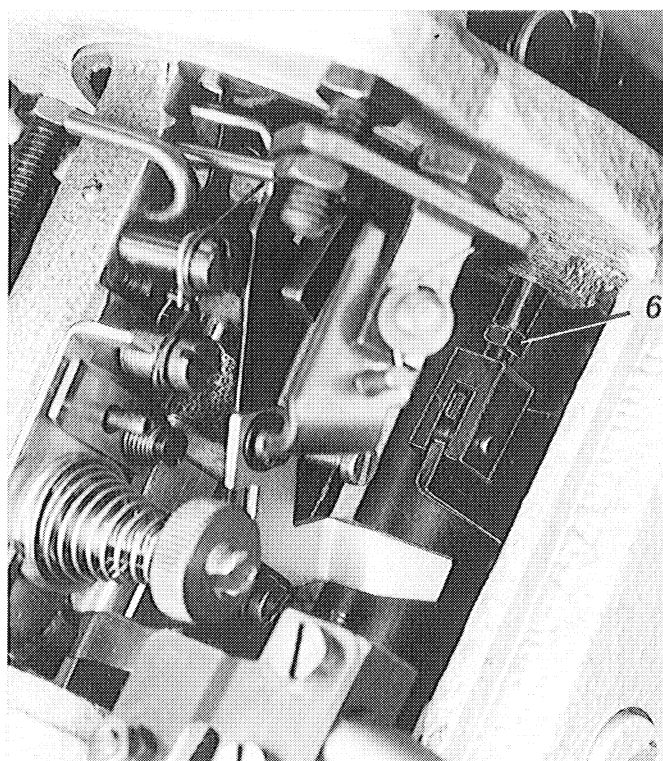
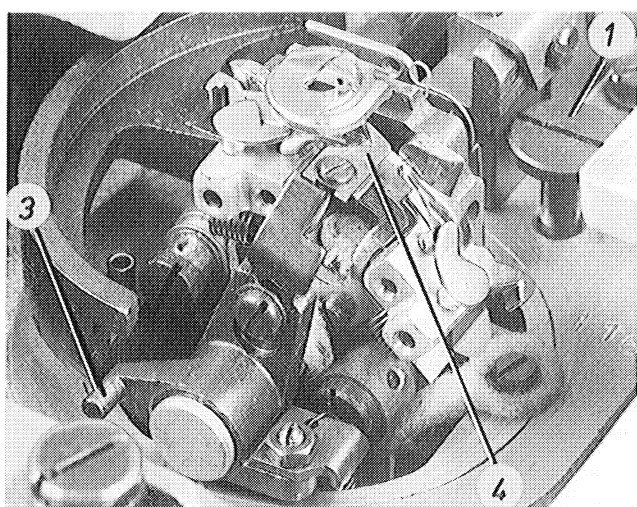



## 28.4 Lifting magnet for the needle thread knife

The stroke of magnet s12 should move the edge 5 of the needle thread knife beyond edge 6 of the throat plate by 1 mm. If the needle thread knife deflection is too wide, the looper thread of the left looper may be damaged.

- Loosen screws 7.  
Lift lever 8 until push rod 11 rests against stop screw 10. Set the shaft 9 tight.  
Tighten screw 7.
- Turn on main switch.

- Enter programme 64 at the switch "Programme" and activate by STOP-push button.
- For magnet s12 enter 12 at the switch "Programme". Switch on the magnet by pressing - key  $\Sigma$  "setting counter".
- Loosen screws 12.  
Align the magnet such that the knife edge 5 projects by up to 1 mm from the throat plate edge 6.  
Magnet down for further deflection  
Magnet up for less deflection  
Tighten screws 12.

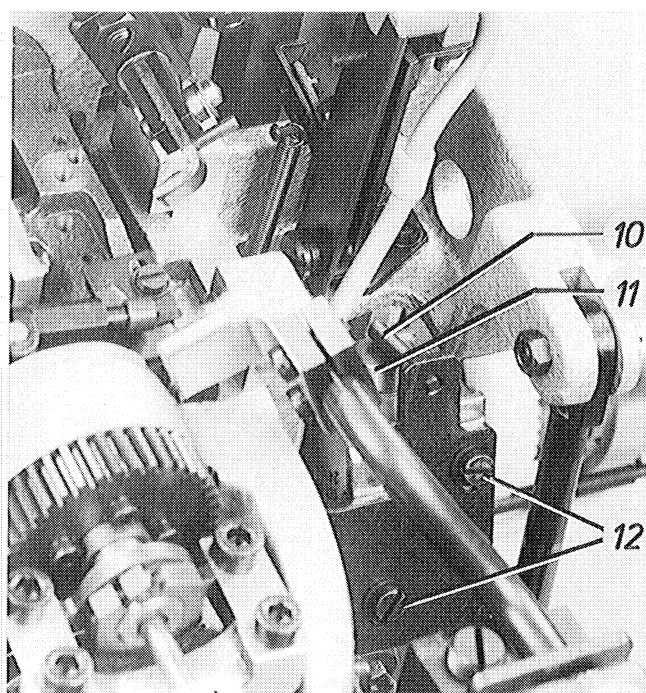
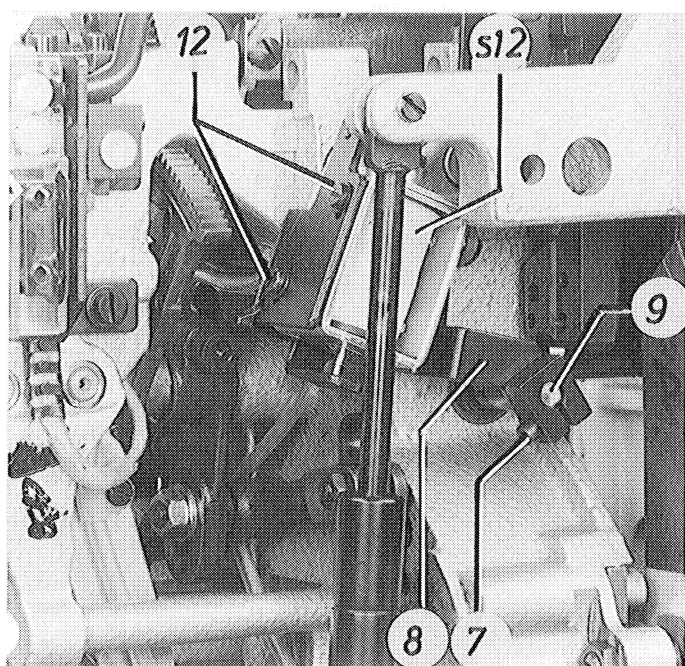
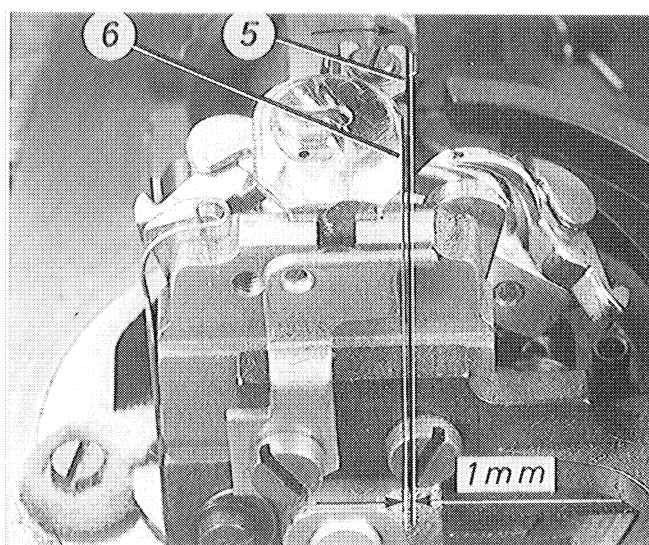

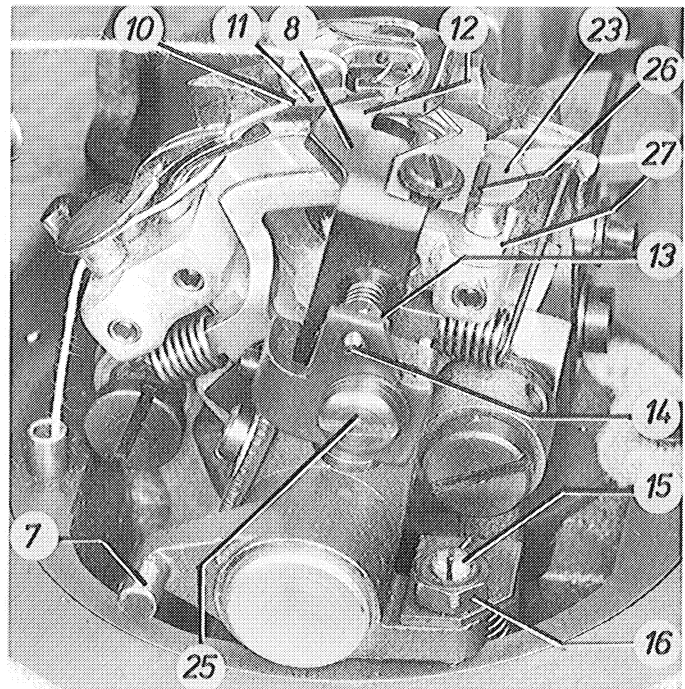
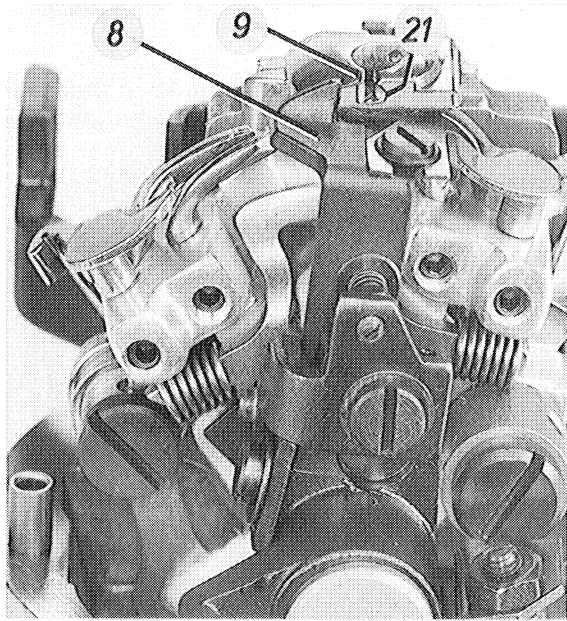



## 29. Looper thread clamp on subclasses -112000, -113000 and -141000



Turn off main switch!

When the sewing cycle is completed, the needle thread knife, which is connected to the looper thread clamp 8, carries out the trimming motion via magnets 12.

Due to this trimming motion thread slot 9 in the throat plate is accessible for a short moment.

While the fabric rest plate moves to its end position, the looper thread is pulled into thread slot 9.

During the backward motion of the needle thread knife the looper thread clamp 8 moves beyond edge 21 of the thread slot by 1 mm and holds the looper thread clamped.

Only during the following rotary motion of the looper block, looper thread and gimp are trimmed by the thread scissors on the right clamping plate.

### Clamping pressure

- Move the fabric rest plate using the hand crank until screw 14 is accessible.
- Loosen lock nut 13.

Turn set screw 14 such that the spring-loaded looper thread clamp 8 does not get stuck at the throat plate edge 10 during its backward motion, but slides across face 11 so that its clamping pressure can become effective.

Check this by moving lever 7 by hand.

Tighten lock nut 13.

### Right end position

- Loosen lock nut 16.

Turn set screw 15 until the right edge 12 of the looper thread clamp located in its right end position has moved beyond the right edge 21 of the thread slot exit by approx. 1 mm.

Tighten lock nut 16.

- Turn the handwheel to swivel the looper block 27 to its extreme left position. The spreader stop 23 must not hit the knife holder 26.

### Height of the looper thread clamp

Loosen screw 25.

Move holder 24 up so that in right end position of the looper thread clamp its upper edge 19 and the top surface 20 of the throat plate are at the same height.

Tighten screw 25.

- Swivel the lever 7 to check, whether the needle thread knife 6 can move unhindered between the throat plate underside and spreader 22 and spreader stopper 23 respectively.
- Loosen screw 18.  
Set height stopper 17 close under holder 24.  
Tighten screw 18.
- Place part of the looper thread in thread slot 9 and make a clamping test by hand.

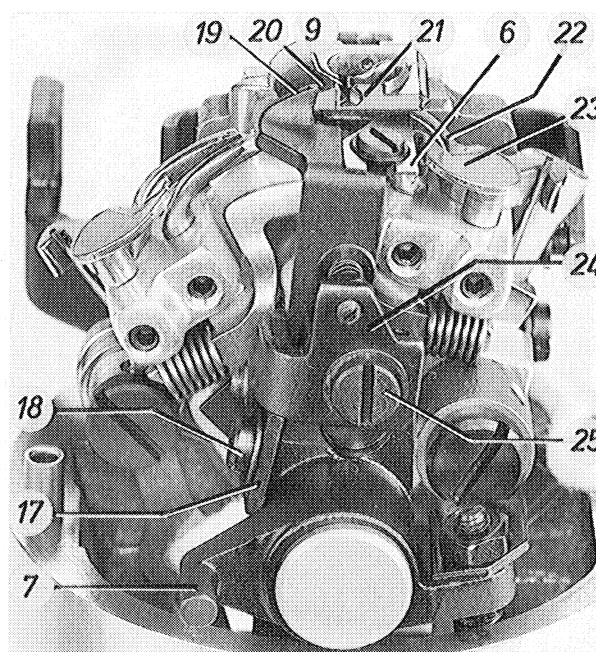



### 30. Looper thread puller on subclasses -112000, 113000 and -141000

Looper thread puller motion 4 and needle thread knife trimming motion occur simultaneously.

The quantity of the pulled forward looper thread must be such that with the 1st needle entry at the seam beginning on the one hand the looper thread is tensioned between looper and throat plate underside, but on the other hand is not yet pulled out of the looper thread clamp during formation of the 1st stitch.

The necessary loose looper thread quantity at the looper is shown in the figure below.

The adjustment can only be made when the 1st stitch is sewn on the threaded and tilted automat using the handwheel and is observed.

- Loosen screws 1 and 2.
- When the looper thread puller 4 rests against pin 3, adjust a corresponding clearance  $x$  between lever 5 and pin 6.
- Tighten screws 1 and 2.
- Turn on main switch.
- Enter programme 50 at the switch "Programme" and activate by STOP-push button.
- Press down pedal and after the 1st stop of the automat sew the 1st stitch using the handwheel and check the thread quantity.

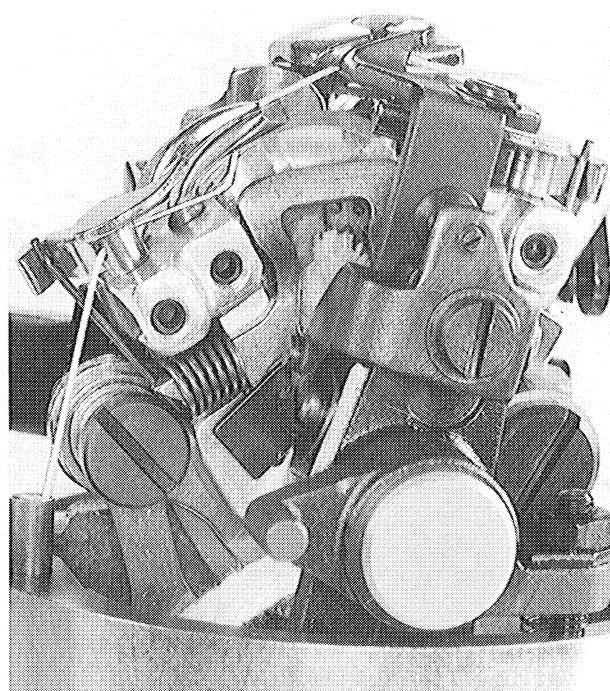
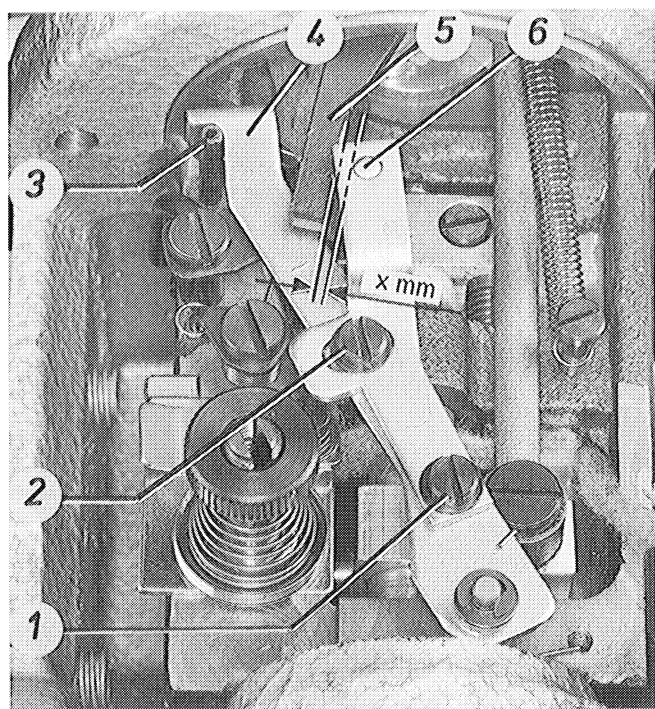



### 31. Trimmer for short looper thread on subclasses -112000 and -113000



**Turn off main switch!**

The rotary motion of the toothed quadrant 12 (see figure on following page) moves the scissor blades 1 and 2 via the rods 13.

The scissor blades should overlap by 1 mm before their turning point.

- Loosen screw 5.  
Set lever 4 parallel to edge 3 of the clamping plates.  
Tighten screw 5.

- Loosen nut 6.  
Set the screw 7 with the spring located underneath such that a good trimming result is obtained with minimum trimming pressure.  
Tighten nut 6.
- Make a thread trimming test by hand.  
Check the knife for smooth motion.  
See section 37 for grinding the knives.  
Continued next page.

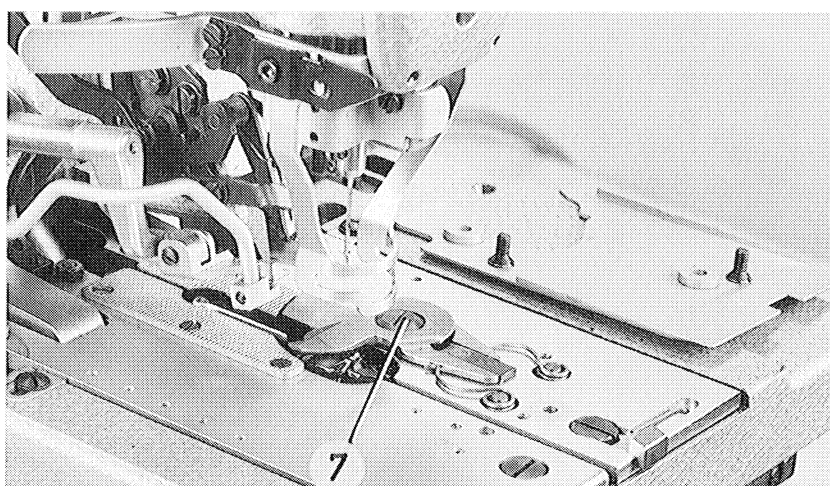
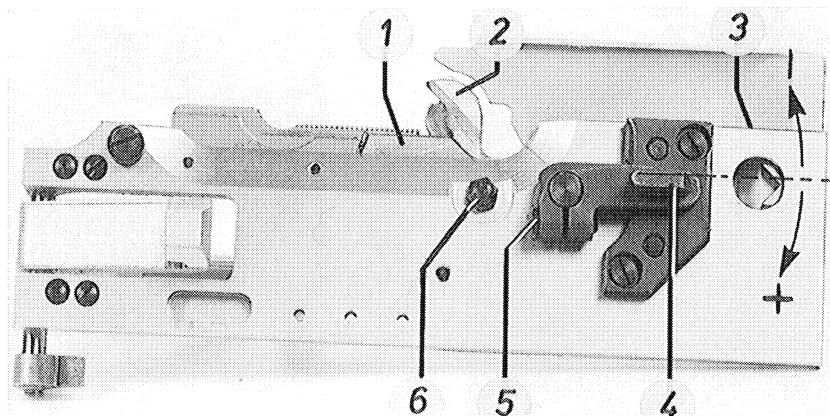



- After loosening stop screw 9 adjust a distance of 1 mm between lever 10 and toothed quadrant 12.
- With the automat in its end position and positioned clamping plates loosen screws 14 and 16.

Adjust a distance of 2 mm between the levers 17 and 18.  
Let stopper 15 rest against the cast iron part of the housing.

Tighten screw 14.

- Turn the hand crank until the machine has run through the buttonhole eyelet that is, the looper block has rotated by 180°.

Pre-adjust a distance of approx. 6 mm between roller 11 on the toothed quadrant and lever 20. Tighten screw 16.

- Turn the hand crank, until the looper thread trimming action starts. This is the case when the cloth clamps of the clamping plates open automatically.

The scissor blades must overlap by approx. 1 mm.

Lever 18 in arrow-indicated direction + more overlap  
Lever 18 in arrow-indicated direction - less overlap

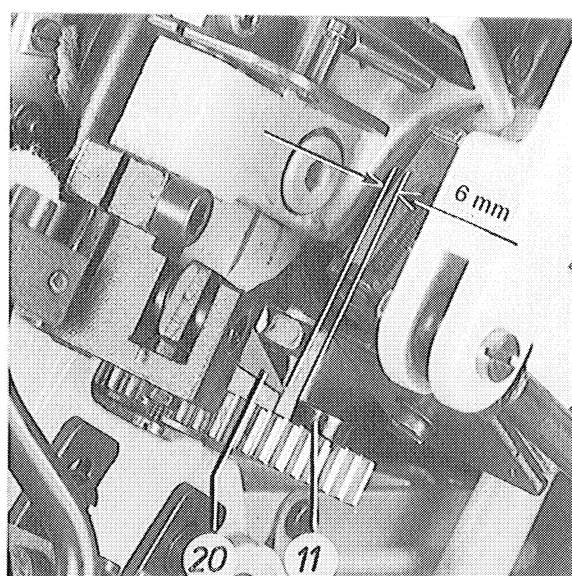
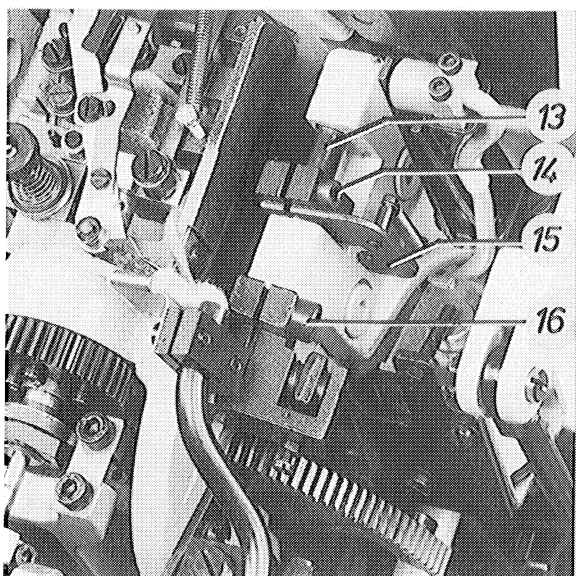
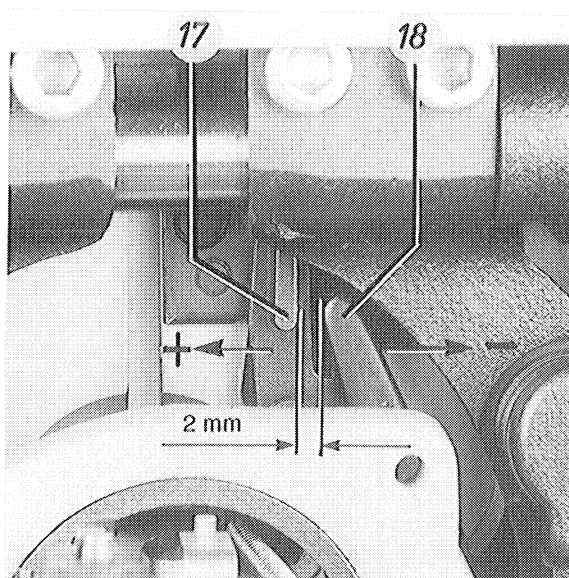
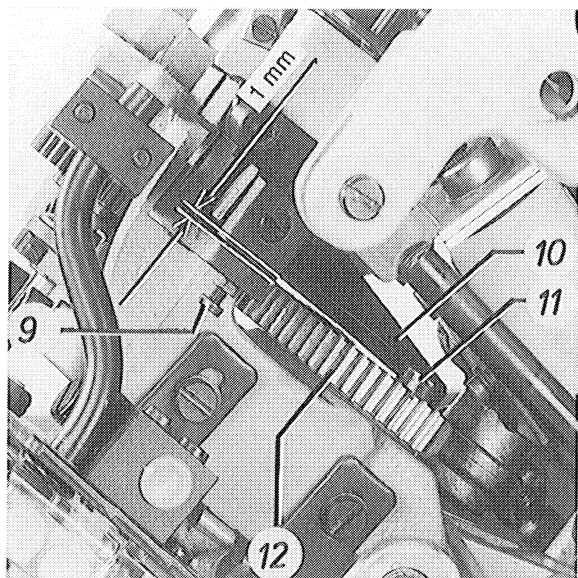



## 32. Trimmer for short looper thread and gimp on subclass -141000



**Turn off main switch!**

The motion of the scissor blades 1 and 2 is actuated by lever 8 just before the end position of the automat together with the rotary motion of the looper block.

Before the turning point the scissor blades should overlap by 1 mm.

- Loosen screw 5.  
Set the lever parallel to edge 3 of the clamping plates. This is considered the pre-adjustment.  
Tighten screw 5.
- Loosen nut 6.  
Adjust screw 7 with the spring located underneath such that a good trimming result is obtained with minimum trimming pressure.  
Tighten nut 6.

- Make a thread and gimp trimming test by hand.  
Check the knife for smooth motion.  
See section 37 for grinding the knives.

- Position the clamping plates.  
Turn the hand crank to check whether the blades overlap by 1 mm during the trimming motion.  
If the lever 4 is slightly displaced from its parallel position, the scissor path is changed.

In arrow-indicated direction to the left = greater path.

In arrow-indicated direction to the right = smaller path.

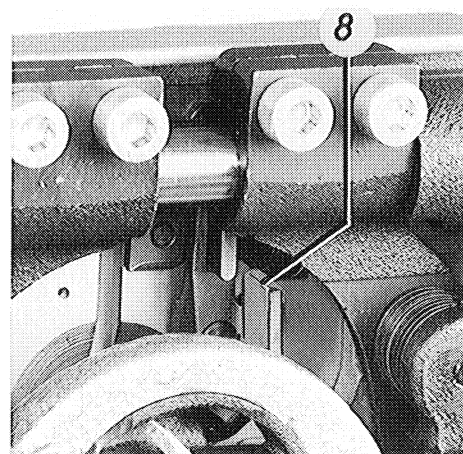
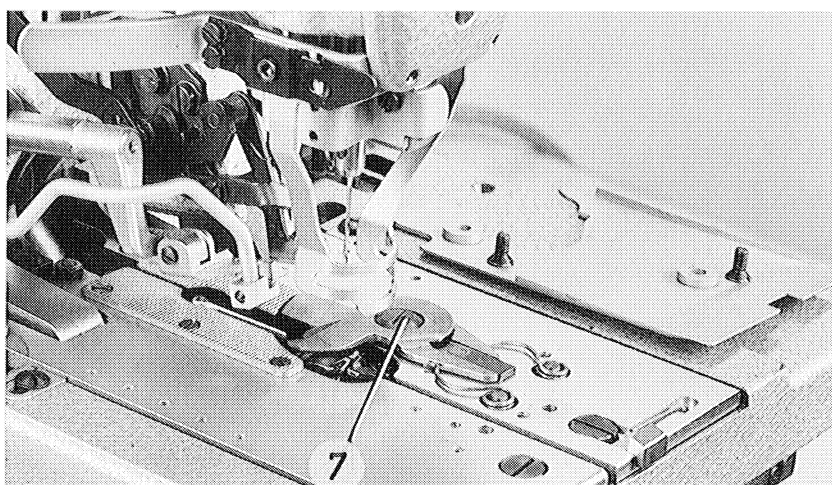
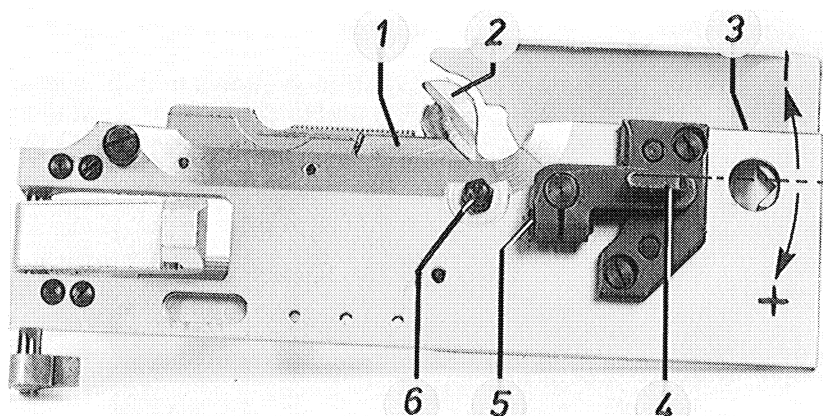



### 33. Gimp pulling device for subclass -141000

 **Turn off main switch!**

The drop weight 1 with the adjustable brake sheet 2 pulls the gimp back to the correct tail length at the seam beginning.

The path of the drop weight must be limited by stop screw 3 such that the gimp is as short as possible at the sewing start, but can be sewn securely.

This is the case when approx. 4 mm of the gimp tail hang out of the gimp hole of the throat plate.

Turn in screw 3 = shorter gimp tail.  
Turn out screw 3 = longer gimp tail.

- Turn the hand crank, until the looper block has rotated by 180°. After turning out screw 4 remove the drop weight 1.
- Loosen screws 5. Adjust a distance of approx. 0.5 mm between edge 6 of the brake sheet 2 and the edge of hole 7. Tighten screws 5.

- Re-fasten drop weight 1 with screw 4. Thread the gimp. At the sewing start drop weight 1 must be pulled up completely by the gimp. This is assured by adjusting the corresponding brake force on set screw 8.

**Attention!**

Set screw 8 is inserted with screw locking fluid and, therefore, turns sluggishly. If the brake force is set too strong that is, the gimp is retained too much, the gimp position changes in the area of the buttonhole eyelet.

- Adjust stop screw 3 such that approx. 4 mm of the gimp tail hang out of the gimp hole after the trimming action.

**Note!**

When the buttonhole length or clamping plates are changed, eg from cut length package L1 to L2, the path of the drop weight must be changed as well.

Experience shows that for a change of the clamping plates stop screw 3 should be turned 1 turn and a little less to change the buttonhole length.

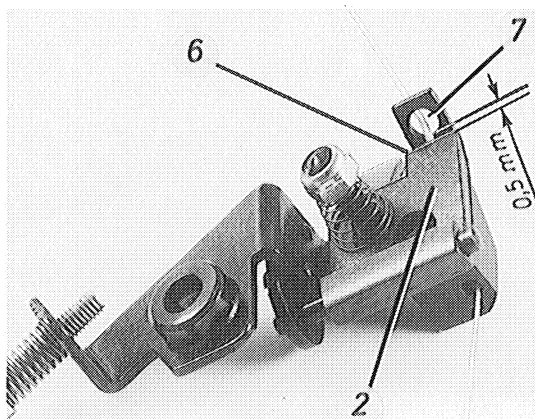
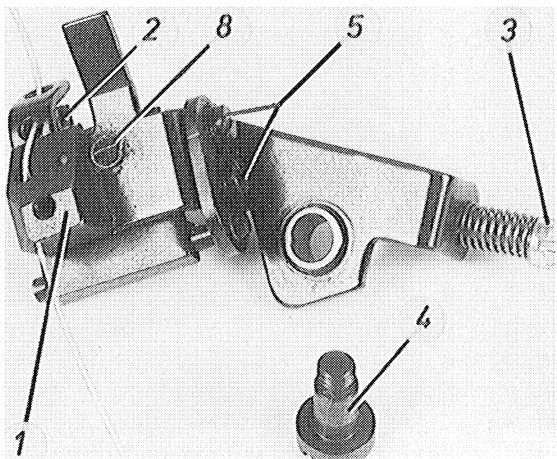
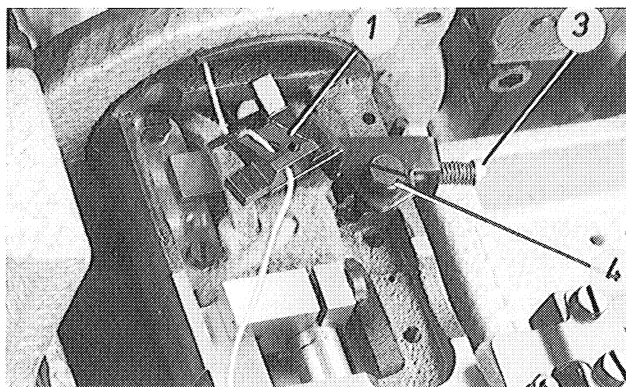



### 34. Cloth holder on subclasses -112000, -113000 and -141000



**Turn off main switch!**

After opening of the clamps the cloth holder 9 holds the material while looper thread and gimp are being trimmed.

Just before the buttonhole is cut the cloth holder descends, when hinge 7 runs onto plate 2.

The cloth holder rises just before the automat end position by the final transport motion of the fabric rest plate. During this, hinge falls into slot 4.

The cloth holder 9 should rest in its bottom position on the cloth clamping sheet 10 without pressure.

- Loosen nut 5.  
Turn out set screw slightly.
- Turn the hand crank, until cutting lever 8 starts to descend.

- Loosen screw 3.  
Adjust plate 2 such that set screw 6 rests on surface 1.  
Tighten screw 3.
- Screw in set screw 6 until the cloth holder rests on cloth clamping sheet 10 without pressure.  
Tighten nut 5.
- Turn the hand crank until the looper thread and gimp trimming action is completed.
- During the subsequent final transport motion of the fabric rest plate, hinge 7 with set screw 6 must fall into slot 4.  
If necessary, slightly correct the position of plate 2.
- Loosen nut 11.  
Turn screw 12 to adjust the stroke height of cloth holder 9 such that with lifted clamps it does not project from the underside of the cloth clamps 13.  
Tighten nut 11.

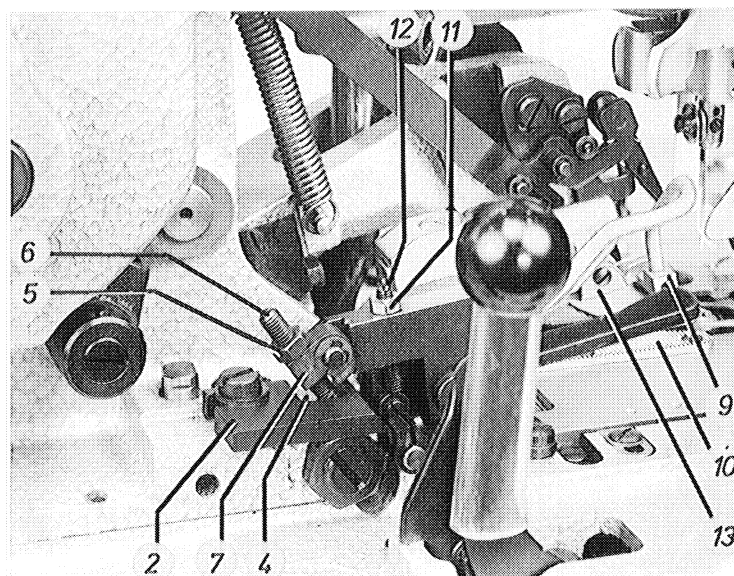
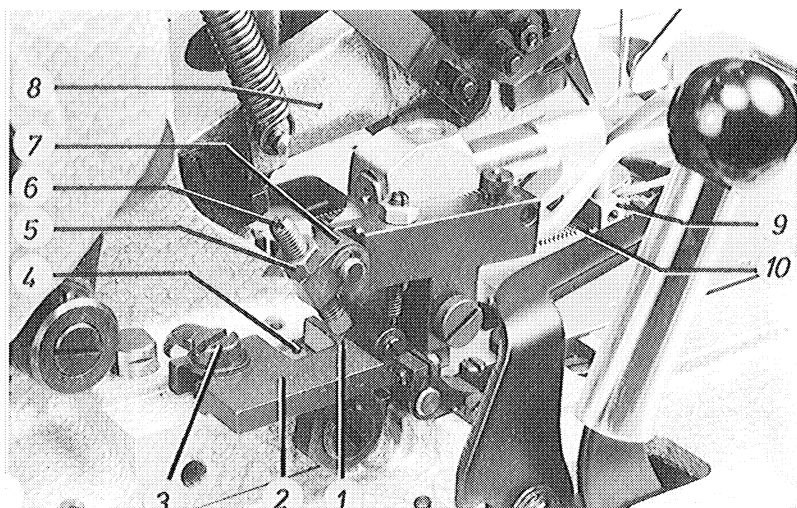



## 35. Mechanical needle thread catcher on subclasses -112000, -113000 and -141000

The needle thread catcher 3 descends and rises with the motion of the cutting lever 4. When it descends hook 1 should move beyond the needle thread by approx. 3 mm. This assures that the needle thread is securely held behind the hook. The felt 2 holds the needle thread tail until the next seam beginning.

- Make the adjustment with threaded threads and positioned material.
- Turn on main switch.

- Enter programme 50 at the switch "Programme" and activate by STOP-push button.  
Tip the pedal several times to sew to the seam end (end of the left buttonhole lip).
- Turn off main switch.  
Turn the hand crank, until the cutting lever 4 has reached its bottom position.
- Loosen screws 5.  
Turn plate 6 such that hook 1 projects from the needle thread to the front by approx. 3 mm.  
Tighten screws 5.

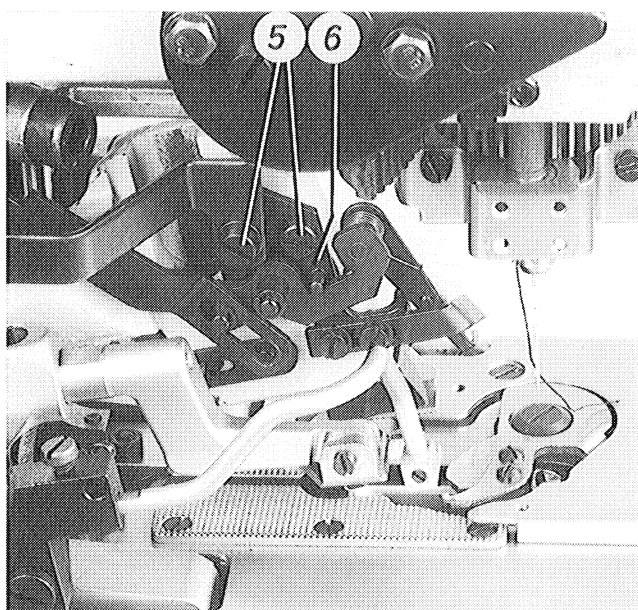
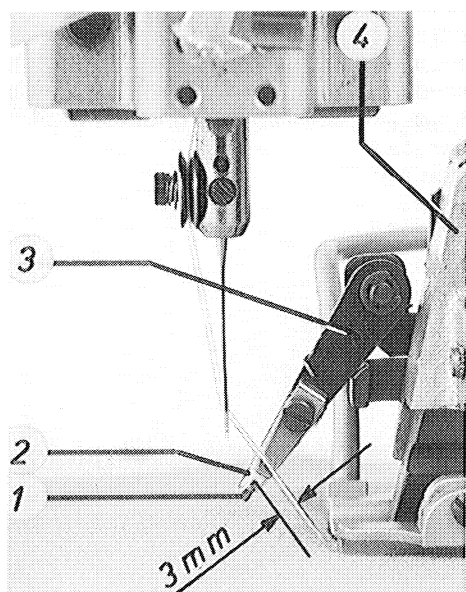



## 36. Trimmer for long looper and gimp threads on subclass -121000



**Turn off main switch!**

Lever 5 for looper thread and gimp trimmer is actuated by the knife drive cam 1.

Blades 2 and 3 should overlap by 1 mm.

The positional relationship of roller 4 and knife drive cam 1 determines the deflection of lever 5.

See section 36.1-36.6 for adjustment recommendations.

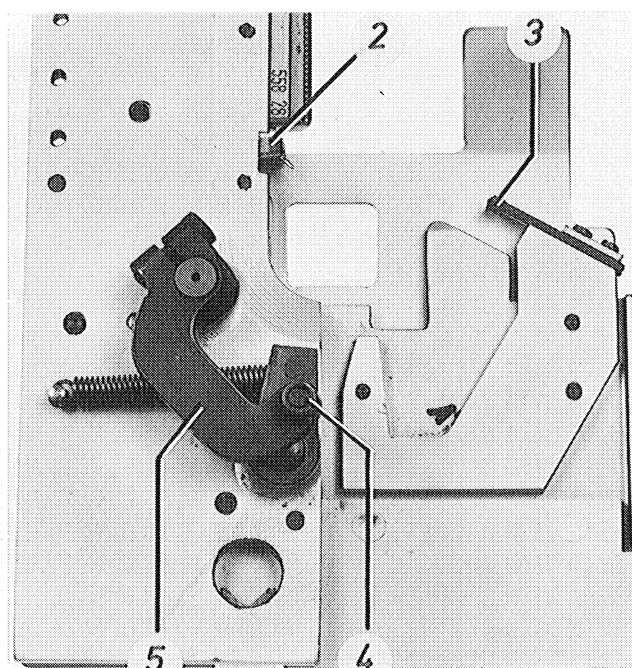
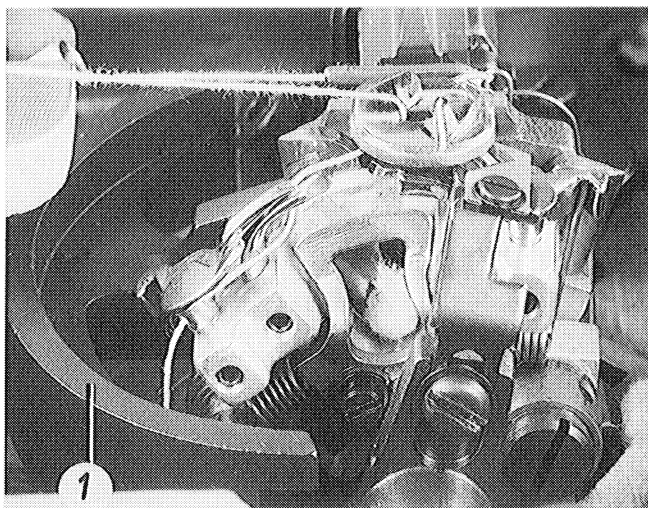



## 36.1 Position of looper thread and gimp clamp



**Turn off main switch!**

The looper thread should be tensioned between the lower clamping spring 5 and clamping piece 6, the gimp thread between the upper clamping spring 1 and clamping piece 6, before the threads are trimmed by the stationary knife 7.

For this, the thread clamp must be in a certain position. The distance between the left edge 8 of the left clamping plate and edge 2 of the thread clamp should be 49 mm. See figure.

If the thread clamp assembly is located too much to the left that means, above the throat plate surface, there is risk of breakage during the rotary motion of the looper block.

The clearance between the thread separator 4 that swivels to the left and the points of thread clamp 2 should only be 0.3 mm.

The actuator 10 opens the clamping spring 5 via pin 11 so that the looper thread is securely positioned before it is trimmed.

The opening width depends on the looper thread thickness.

If the looper thread clamp opens too much, the looper thread may move back after it has been trimmed.

- Loosen fastening screws 9 for the thread clamp.
- Adjust a distance of 49 mm between the left edge 8 of the clamping plate and right edge 2 of the thread clamp using a slide gauge. First, tighten the fastening screws 9 only slightly.
- Position the left and right clamping plate.
- Bend the thread clamp until the distance between clamp and thread separator 4 is approx. 0.3 mm.  
Remove the right and left clamping plate. Check the 49-mm-distance again. Tighten fastening screws 9.
- Align the height of the actuator 10 such that the clamping spring 5 is opened depending on the looper thread thickness.
- Bend the clamping spring 5 to adjust its pressure such that the looper thread is held lightly clamped after it has been trimmed and does not move back.

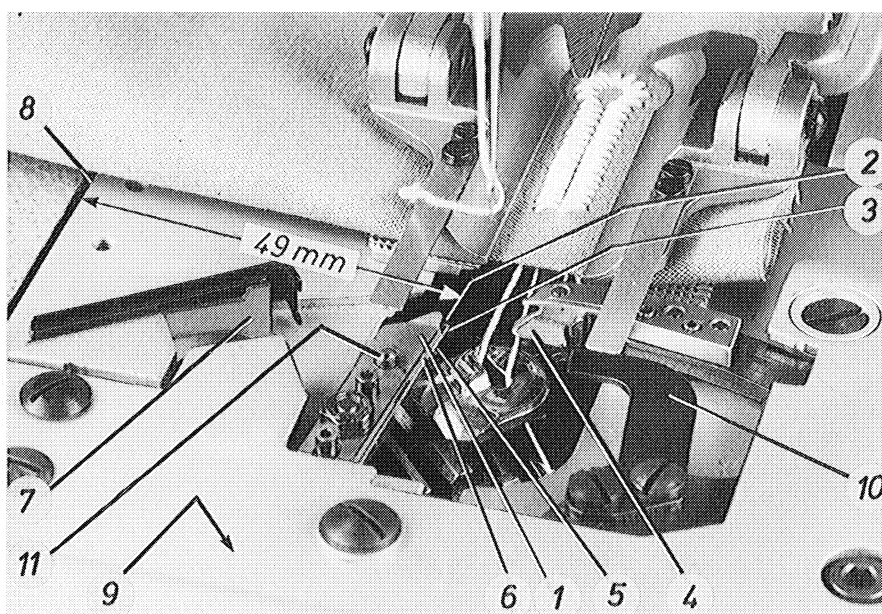



## 36.2 Trimming pressure and trimming motion of the looper thread and gimp trimmer



**Turn off main switch!**

Adjust the trimming pressure just enough to enable secure trimming of threads.

To accomplish this, move the stationary knife 1 accordingly toward the swivelling range of the mobile knife 2.

### Attention!

Do not work with excessive trimming pressure but, if necessary, slightly bend the knife lever 3 or grind blunt knives as described in section 37.

The position of the roller 4 at the actuation lever 5 determines the swivelling motion of the mobile knife 2. The distance between edge 6 of the clamping plate and the outside of the roller should be 53.5 mm (pre-adjustment).

If the mobile knife 2 has reached its extreme position to the left (turning point), the blade of the stationary knife should be located 1 to 2 mm above the blade of the mobile knife.

In this position the mobile knife must still be movable by hand in direction of trimming. A slight play must be perceptible.

If this is not the case the blocked knife may lead to breakage.

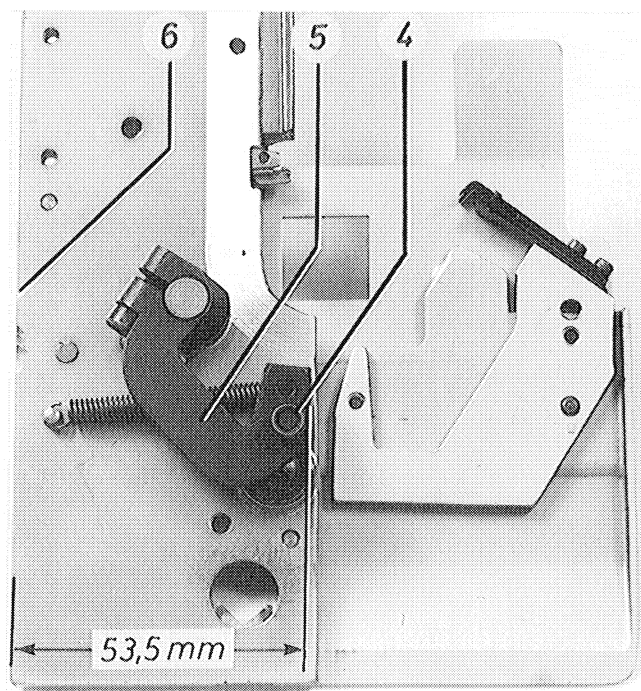
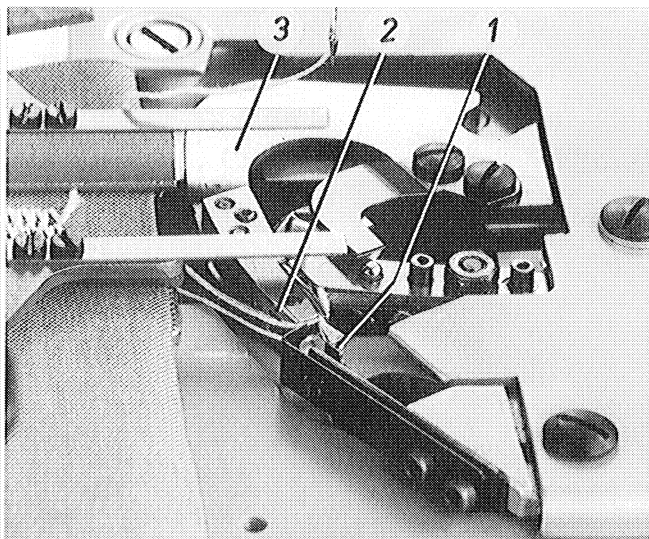

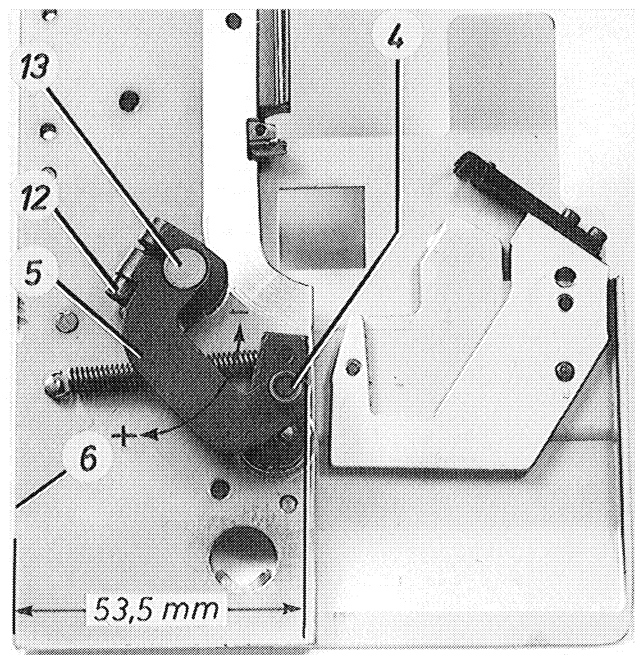
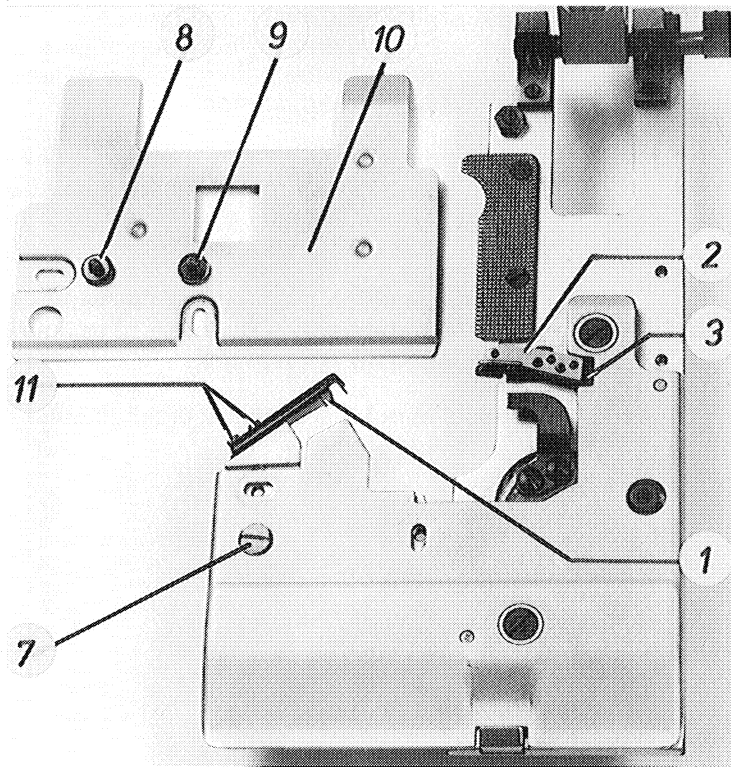



- Unscrew screws 8 and 9. Remove cover 10.
- Loosen screw 7 marked yellow. Move the mobile knife 2 to the left by hand and hold in its left position.
- Move the stationary knife 1 with light pressure until it rests on the mobile knife. Tighten the screw 7 marked yellow.
- Trim the thread by hand as a test. If the blades are not parallel to each other, slightly bend knife lever 3.

Now the yellow screw 7 should not be loosened any more.

- Loosen screw 12. To adjust a distance of 53.5 mm between edge 6 of the clamping plate and the outside of roller 4 turn the actuation lever 5 on axis 13. Tighten screw 12. First position the left and then the right clamping plate.
- Turn on main switch.
- Enter programme 50 at the switch "Programme" and activate by STOP-push button.
- Tip the pedal several times to stop the automat at seam end position (end of left buttonhole lip).
- Turn off main switch and swing up the automat.
- Turn the hand crank slowly until roller 4 is positioned close to the front of knife drive cam 14. See figure a.

When turning further the roller must not hit cam point 15, but should always roll on the inside of the cam and should only be lightly actuated by the cam beginning.

If this is not the case, correct the position of actuation lever 5 accordingly before turning further.

- Turn the hand crank further until roller 4 reaches the end of drive cam 14. See figure b.
- In this position the mobile knife reaches its extreme position (turning point). The mobile knife 2 must still be slightly movable to the left by hand.

### A blocked knife may lead to breakage!

Adjustment of roller 4 in arrow-indicated direction:

- + = greater deflection to the left
- = smaller deflection to the left

- Turn the hand crank to move the mobile knife 2 again to its left end position. Loosen screws 11. Position the blade 1 of stationary knife 1 by 1 to 2 mm above the blade of the mobile knife 2. Tighten screws 11. Re-screw on cover 10.
- In the case of jammed knives the knife lever 16 is pushed back by angle 17. This happens after the trimming, when the spread clamping plates open and move back to their basic position.

When the knife lever 16 is on its extreme position to the left and the clamping plates are spread, move the angle closer until a distance of 0.3 mm has been established.

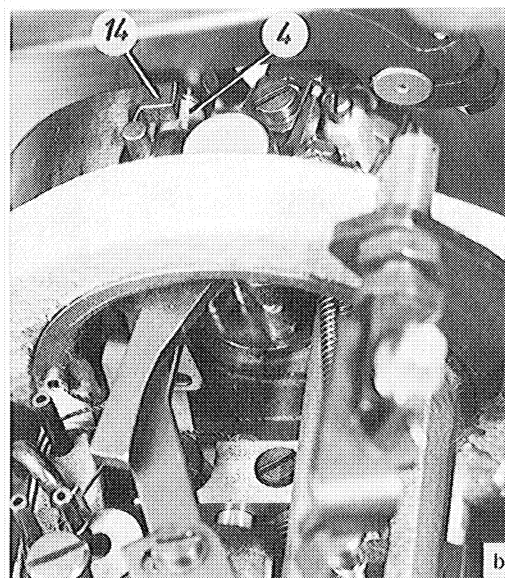
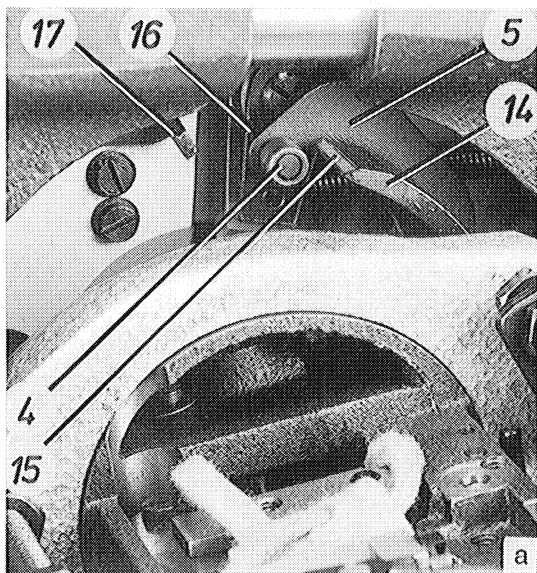



### 36.3 Thread separator for looper thread and gimp



**Turn off main switch!**

The separator point 2 must slip between looper thread 4 and gimp 5.

To enable this, both threads must be tensioned. The gimp thread is tensioned by spring 10 at the looper block.

If necessary, guide thin or smooth gimp threads through the three holes in the top arm of the thread stand.

During the motion of throat plate and thread catcher 1 with thread separator 2 the looper thread slides into slot 8 of the throat plate.

Therefore, the looper thread is securely guided toward the lower clamp 6 and the gimp toward the upper clamp 7.

If the thread separator is 5 to 7 mm in front of the cutting edge of the stationary knife 9, the looper thread should move out of slot 8. Before being trimmed, both threads are pulled into the clamps 6 and 7 by the final motion of the thread catcher 1.

- Position the material and start the automat. Heel back the pedal to stop the automat at the seam end (end of left buttonhole lip). Turn main switch off!
- Turn the hand crank of the automat until the separator point 2 is located in front of looper thread and gimp.
- The separator point 2 must slip between looper thread and gimp. If necessary, loosen screw 3 and adjust the thread separator 2 accordingly.

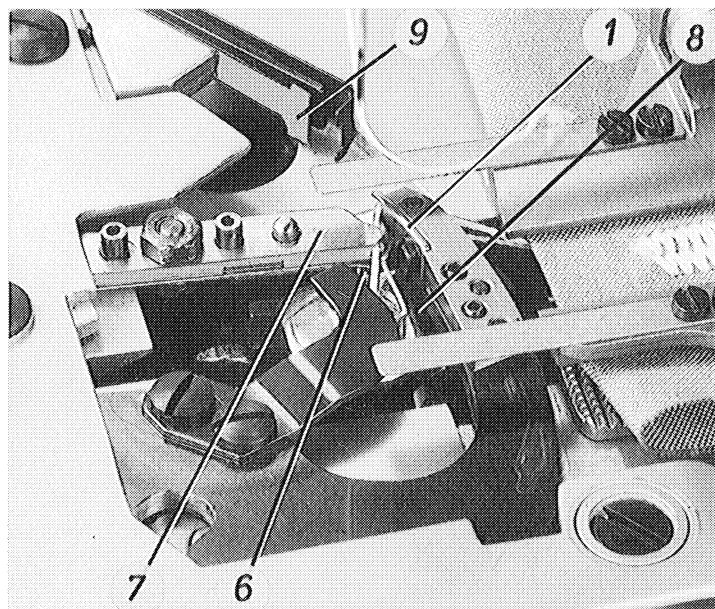
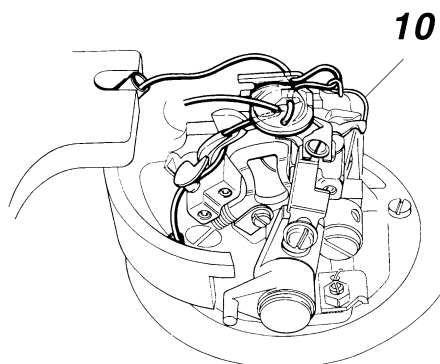
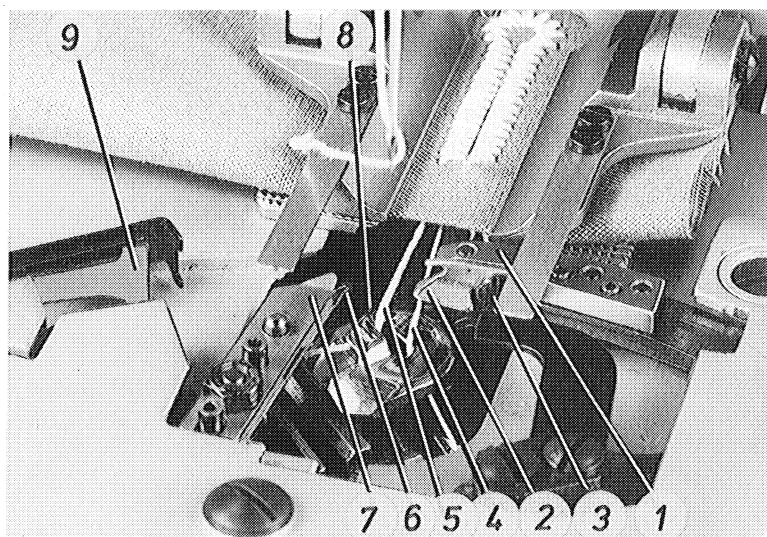



## 36.4 Thread clamp and thread deflector



**Turn off main switch!**

The clamping spring 6 for the looper thread is adjustable after loosening nut 5 by turning screw 2.

Depending on the looper thread thickness adjust the clamping spring 6 such that the thread can be pulled under it without being hindered. The spring must not be set tight with screw 2.

The looper thread must, however, be held so as to ensure a securely tightened seam beginning.

If necessary, bend the clamping spring 3 to adjust its force.

It should also be easy to pull the gimp thread under clamping spring 3, but it should only be clamped lightly.

The deflector 8 is mounted above the stationary knife 9. It assures that the looper thread tail does not slip between the knife 9 and the back of the thread catcher 1, but is guided beside or into the thread catcher.

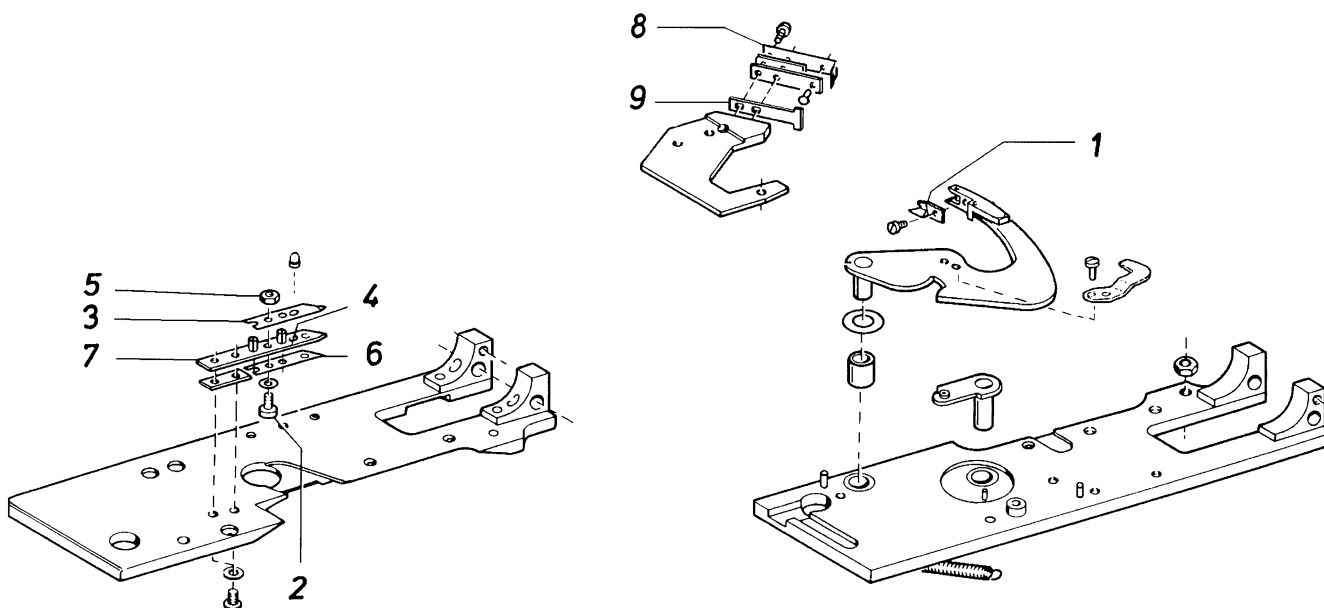
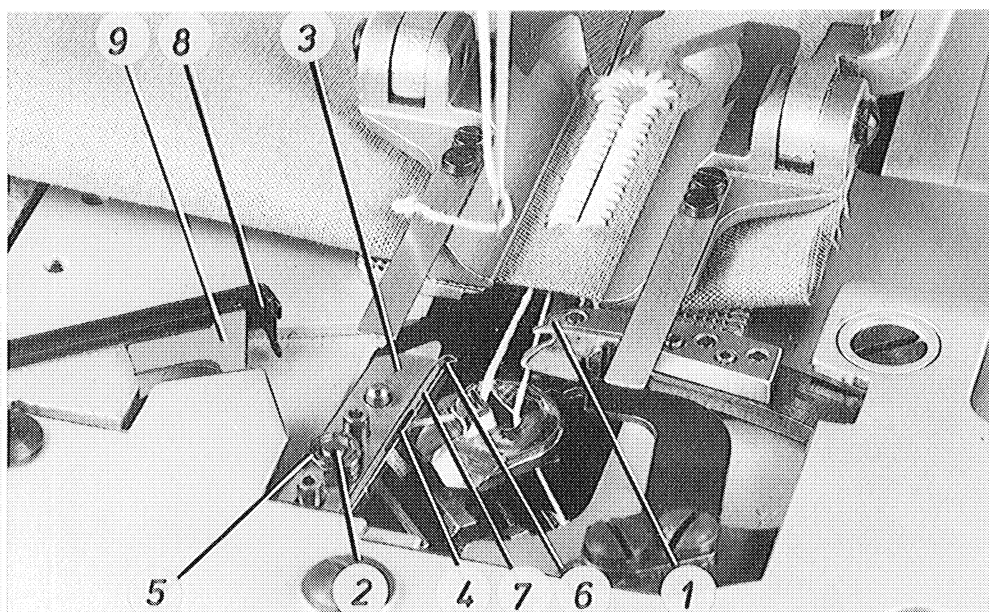



## 36.5 Looper thread puller for the trimming action



**Turn off main switch!**

The looper thread must be pulled forward to assure that the thread separator can guide a sufficient amount of loose looper thread up to the stationary knife without tension, thus avoiding torsion of the sewn buttonhole.

When the sewing cycle is stopped and the rotary motion of the looper block starts, the thread pulling lever 9 is actuated via pawl 2 and cam 1.

To obtain a sufficient thread quantity, the thread pulling lever 9 must have moved up to a distance of approx. 2 mm toward connecting rod 10, when pawl 2 is at the highest point of cam 1.

To assure that the cam moves up on the pawl unhindered, a distance of approx. 34 mm must be adjusted between housing 4 and the upper edge 3 of the fork.

- Loosen lock nut 5.  
Turn pawl 2 up or down accordingly until the distance between housing 4 and the upper edge 3 of the fork is 34 mm.  
Tighten lock nut 5.
- Turn the hand crank until the looper block is in the position shown in the figure and pawl 2 has moved up on the highest point of cam 1.  
Loosen clamping screw 6 slightly.  
Turn thread pulling lever 9 such that its distance to connecting rod 10 is approx. 2 mm.  
Tighten clamping screw 6.  
Tightening torque = 3.3 Nm!
- In rest position of the thread pulling lever 9 adjust the release sheet 7 for the looper thread tension with a small distance to roller 8.

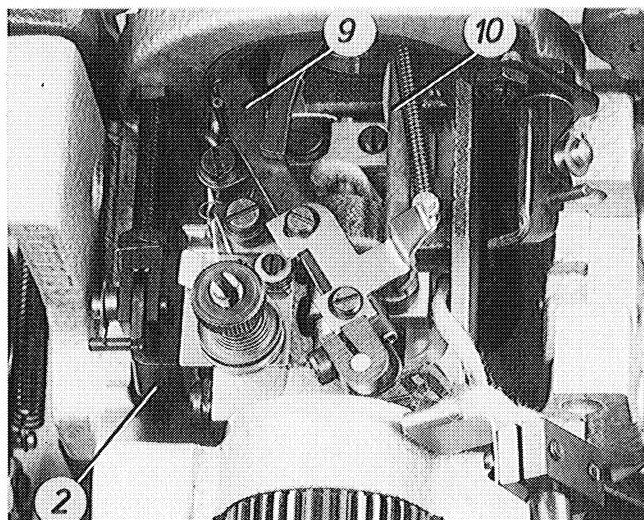
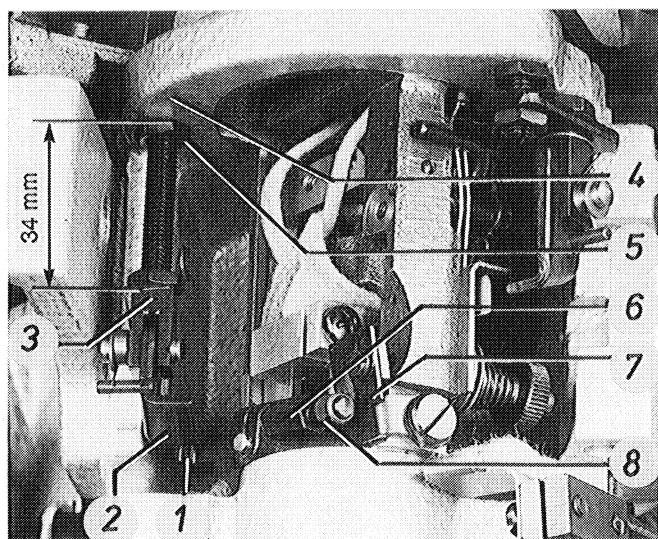



## 36.6 Looper thread puller for the secure seam beginning



**Turn off main switch!**

To prevent the looper thread from being pulled out of the thread clamp during the fast transport phase of the fabric rest plate before the actual seam beginning, the necessary thread quantity must be pulled forward by the thread pulling lever 1.

For this, the looper thread clamp on the left clamping plate must be adjusted tight enough to ensure that thread is only pulled from the looper thread tension.

Furthermore, the quantity of the pulled forward looper thread must be calculated such that during the first needle entry at the seam beginning on the one hand the looper thread is tensioned between the undersides of looper and throat plate, and on the other hand is not yet pulled from the looper thread clamp.

The figure below shows the approximate amount of loose thread required at the looper.

The adjustment can only be made when the 1st stitch is sewn using the handwheel on the threaded and tilted automat and is observed.

When changing from short to very long button-holes, the thread quantity must be changed as well.

The looper thread is pulled forward just before the end position of the automat by pawl 5 and thread pulling angle 6.

To ensure that the pawl moves up on the thread pulling angle unhindered, the distance between housing 3 and pawl bottom edge 5 must be 42 mm.

- Loosen lock nut 4. Turn pawl 5 up or down accordingly until the distance between housing 3 and pawl bottom edge 5 is 42 mm. Tighten lock nut 4.
- Loosen screws 2 and 7. First, adjust the thread pulling angle 6 that it centres in the elongated hole. Tighten screws 2 and 7.
- Turn on main switch.
- First, sew a cycle. Enter programme 50 at the switch "Programme" and activate by STOP-push button.

After pressing down the pedal the automat stops before the seam beginning. Turn the handwheel to check the thread quantity, as shown in the figure, when the needle enters the material for the 1st time.

- If necessary, correct the position of the thread pulling angle 6.

In arrow-indicated direction + = more looper thread  
In arrow-indicated direction - = less looper thread

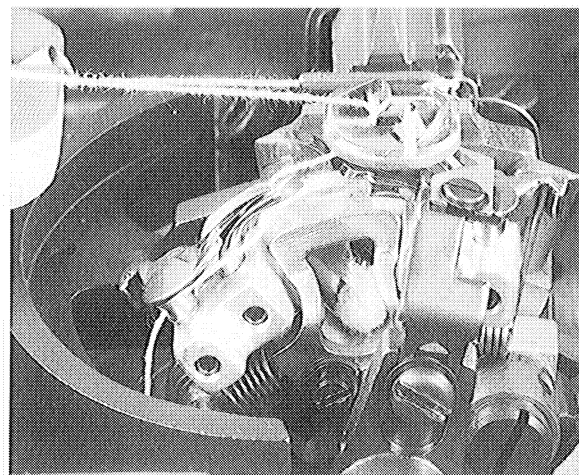
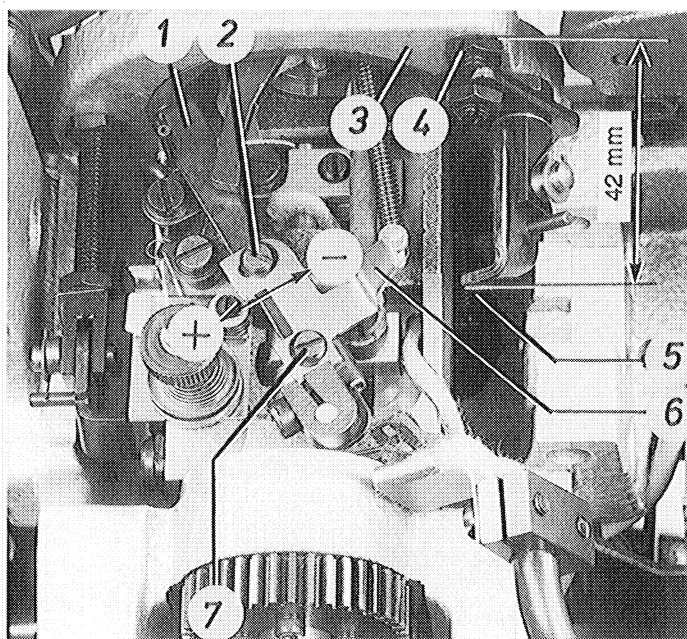



### 37. Grinding the thread trimmer knives

 **Turn off main switch!**

When the knives loose their sharpness after a certain operating time, they have to be re-ground or new original DÜRKOPP ADLER knives need to be ordered under the respective order no. The looper thread trimmer must not be operated with excessive trimming pressure.

Observe the cutting angles specified below when grinding the blades.

**Needle thread knives for all subclasses, order no. 558 9011**

Loosen screw 3.

Remove needle thread knife 2.

Grind blade 1 according to the specifications in the dimensioned sketch shown below.

Mount the needle thread knife as described in section 28.2.

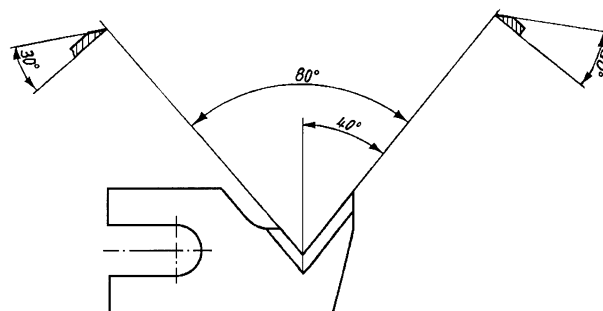
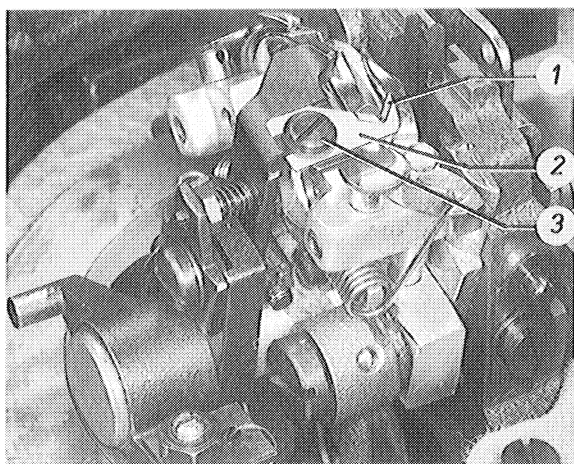

**Scissor knives for subclasses -112000 and -113000 depending on cut length as well as -141000 depending on the cut length package L ..**

Order numbers in the case of subclasses 578-112000 and -113000

Cut length	Upper knife	Lower knife
16 and 18 mm	558 8868	558 8869
22, 24, 28 and 34 mm	558 8878	558 8879

Order numbers in the case of subclass 578-141000

Cut length package	Upper knife	Lower knife
L1	558 8816	558 8817
L2	558 8858	558 8859
L3	558 8868	558 8869
L4	558 8878	558 8879

Remove the scissor knives 4 and 5.

To do this, remove the nut located at the underside for the pressure screw 3. Unhook springs 1 and 2 and turn out pressure screw.

Grind the blades of the scissor knives according to the specifications in the following dimensioned sketches.

Assemble the scissor knives as shown in the figure below and check their adjustment according to section 31 or 32.

A thread guide sheet is fastened with two screws on the upper scissor knife 4. It guides the threads into the opened scissors.

If the guide sheet on subclass -141000 needs to be replaced make sure to observe with which cut length package L .. the sewing automat is equipped.

Guide sheet for L1 - order no. 558 8820.  
Guide sheet for L2 - order no. 558 8860.  
Guide sheet for L3 - order no. 558 8870.  
Guide sheet for L4 - order no. 558 8880.

Fastening screw - order no. 211 256.

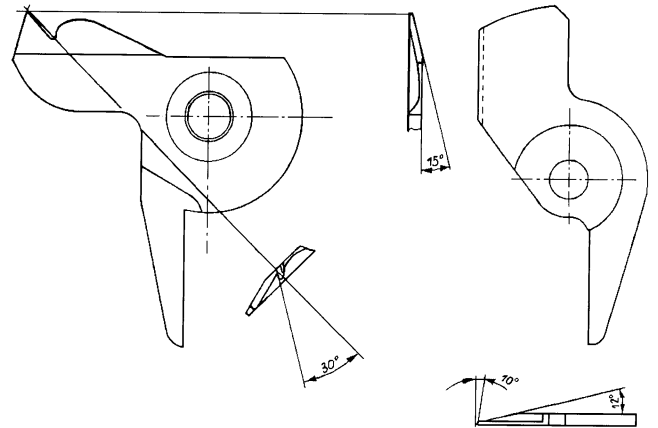
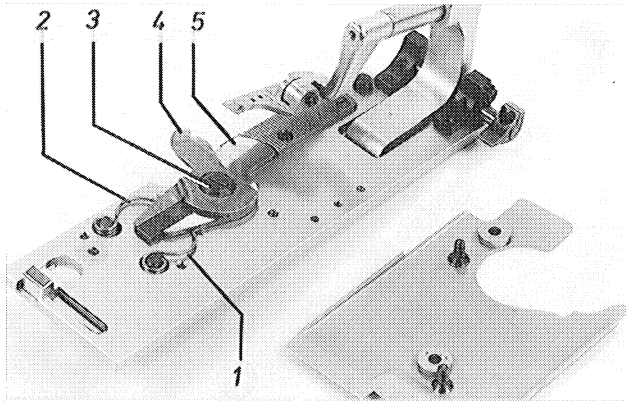

**Knife for trimmer for long threads subclass - 121000, order no. 558 7892**

Screw out screws 7.

Remove knife 6 with thread deflector and intermediate sheets.

Grind the blade of the stationary knife as specified in the dimensioned sketch below.

Mount knife and adjust it according to section 36.

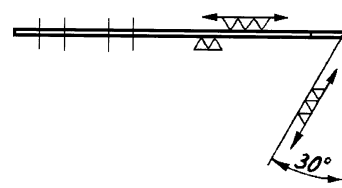
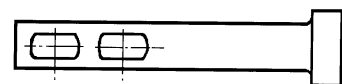
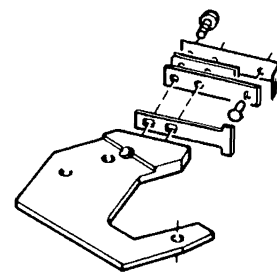
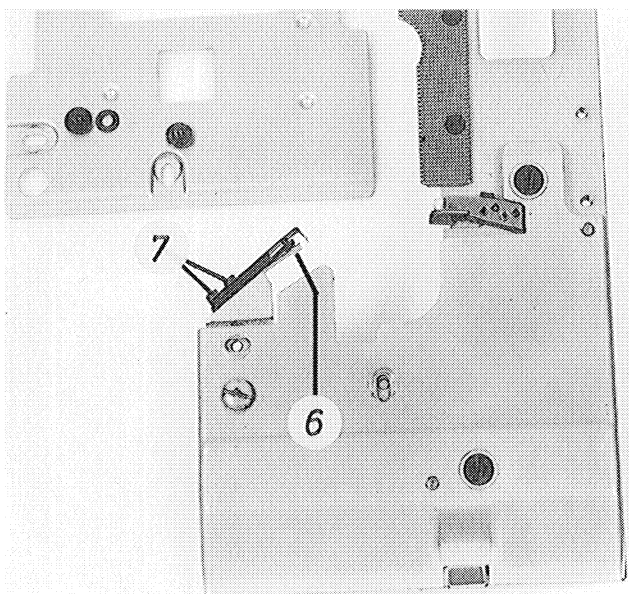

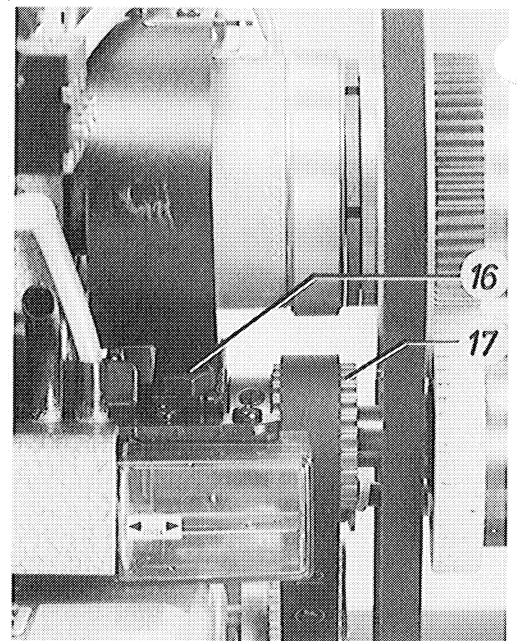
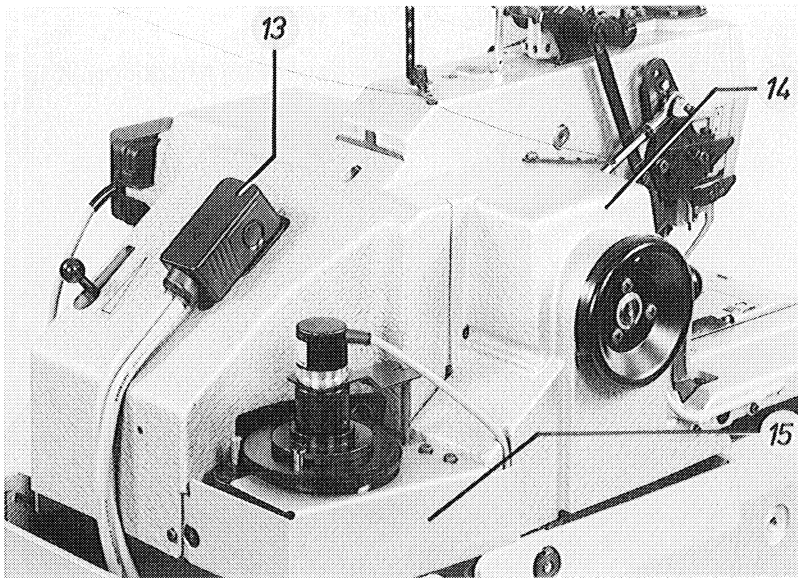
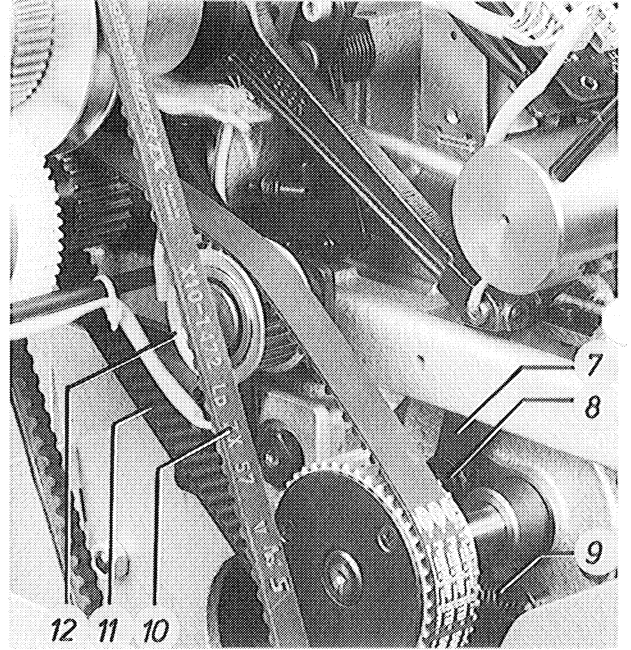
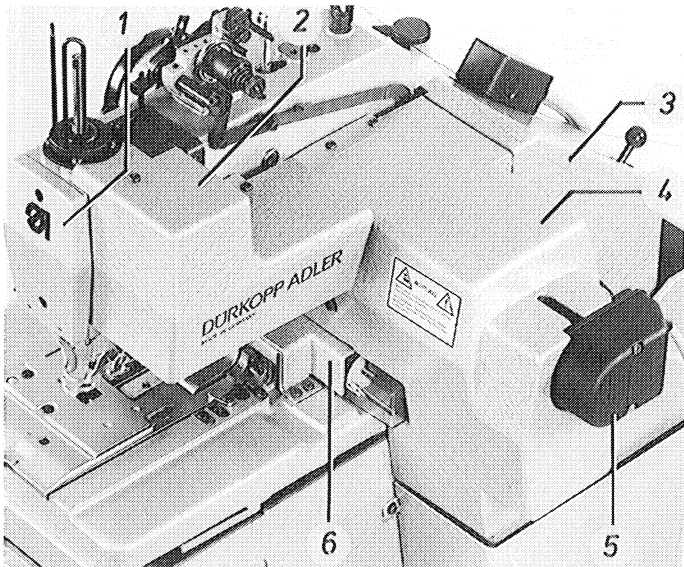



## 38. Removing and mounting the machine arm



**Turn off main switch!**

When the sewing automat gets stuck, the cause may be found in the machine housing, eg the remainder of a needle or another object may be blocked in the main control cam.

Before removal of the machine arm, first separate the feed lever 7 from the machine head drive. To do this, remove screw 8, the washers in between and the inner bushing.

Then turn the handwheel to check whether the machine arm operates smoothly. If it does operate smoothly, the cause may be found in the machine housing.

The part that is blocked in the groove of the cam may fall out when the hand crank is turned in reverse direction.

Before reversing the hand crank remove tension spring 9.

### Removing the machine arm

(Also note the reference numbers in the figures below).

Remove the following parts one after the other:

- Clamping plates and needle.
- If existing, the right cover for the toothed quadrant.
- Front cover plate 1 and synchronizer 5.
- The right cover 4, the rear cover 3, covers 6 and 15.
- The control box plug 13.
- Handwheel and left cover 14.

- If the machine is equipped with a needle thread catcher, remove the PK4-line 21 of the solenoid valve block.  
The electrical cable 20 fastened with hose clip and the PK4-line from the machine arm.
- Loosen all marked cores from the clamping ledges L1, L2, L3 and the central plug connection 22.
- Unscrew screws 18 and 19 and remove the needle thread catcher.
- Pull out the upper part of the gas cylinder. To do this, turn out screw 29.
- After turning out the screws 27, remove the belt tensioner 28 and timing belt 26.
- After loosening screw 16 and swivelling the belt tensioner 12, remove the timing belt 11.
- The motor V- belt 10.
- Attention! The sliding blocks may fall out of the frame 25. Secure the blocks before removing the machine arm.
- The tension spring 9.
- Screw 8 of the feed lever.  
Attention! Do not loose washers and inner bushing!
- Cover 24 for the oil felt.
- Shaft encoder 23 and all control cams.
- Unhook the tension spring 41.
- Lever 38 after unscrewing the screws 37 and 39.
- The proximity switch b10 after screwing out its fastening screws.
- The three arm fastening screws 32.

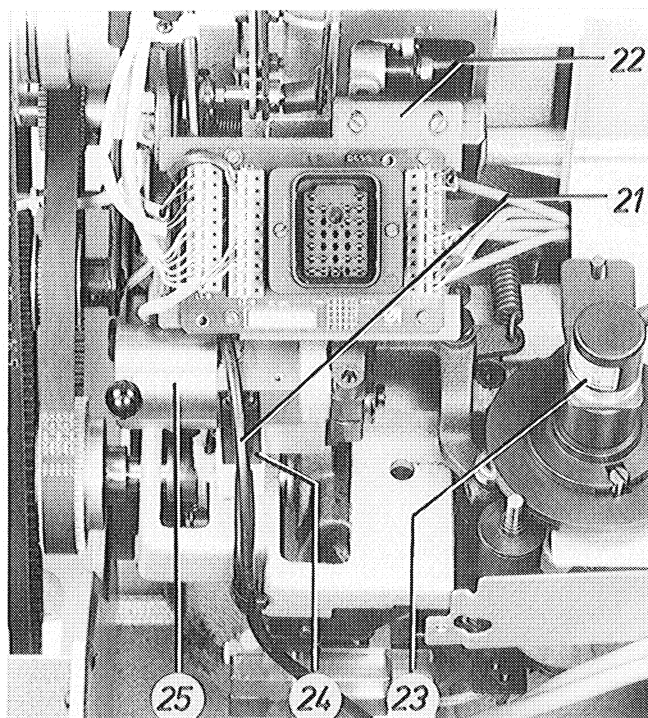
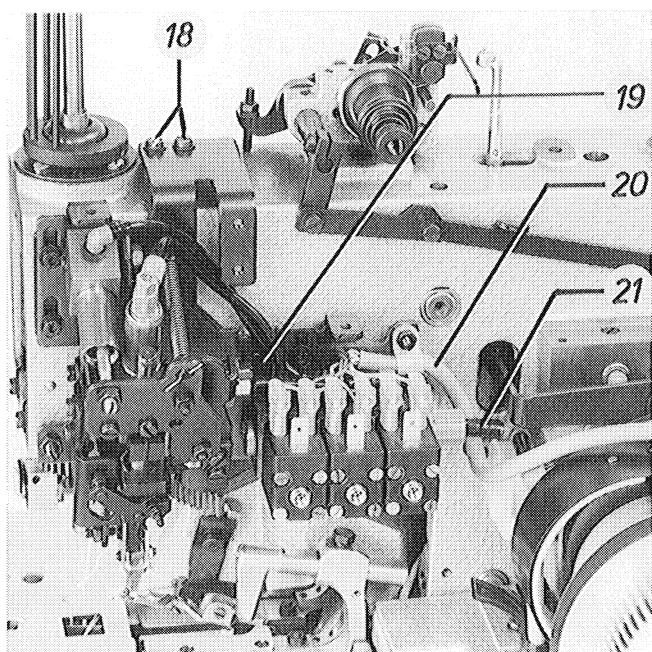

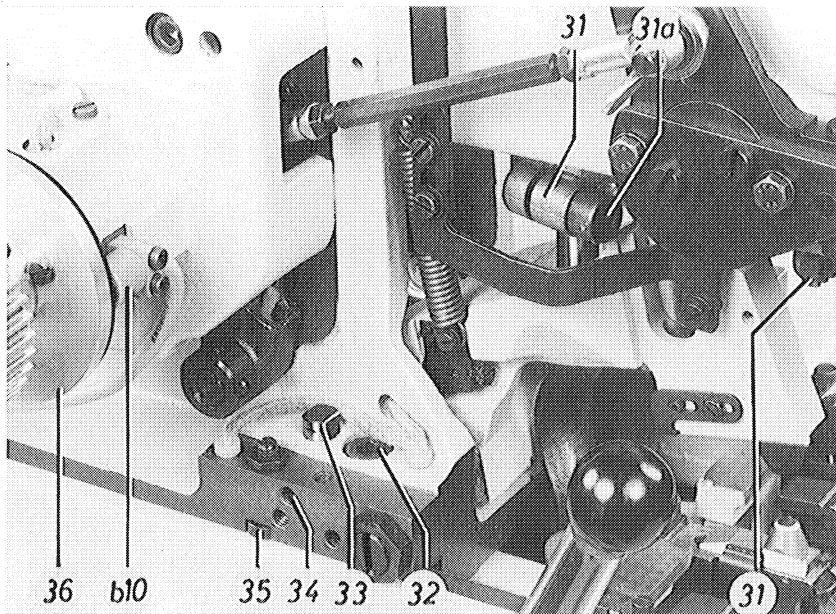
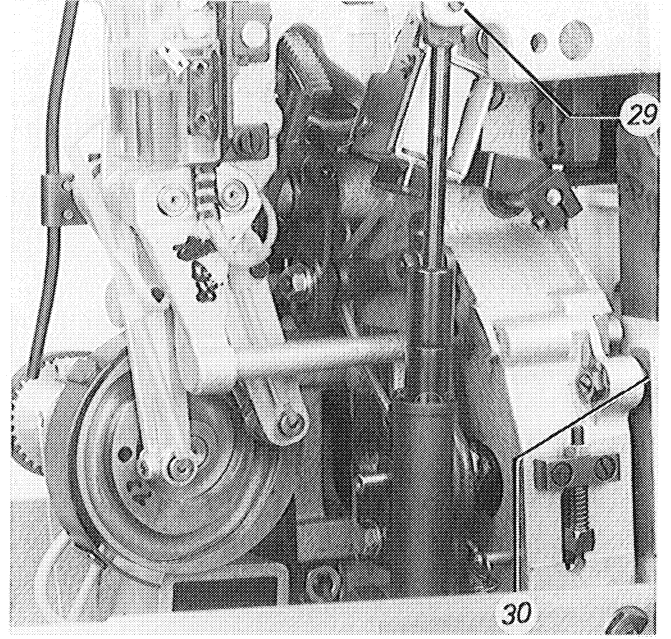
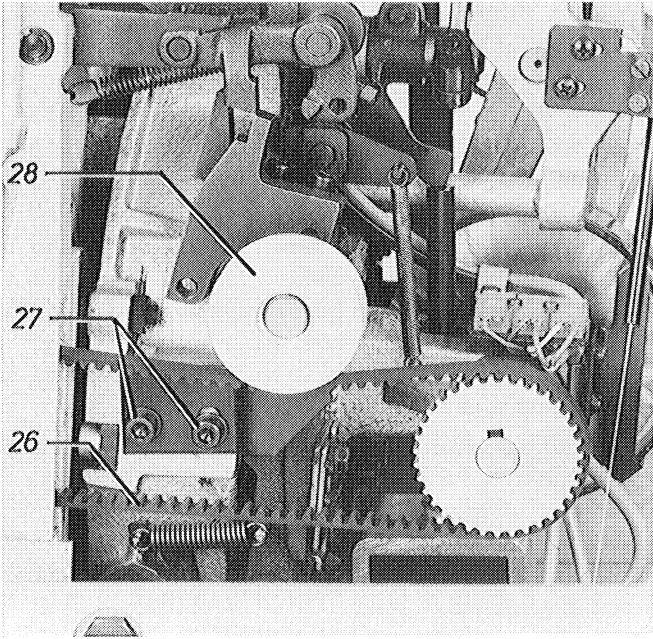



- After loosening screw 34, remove the adjustment pin 33.
- The centering screw 40.
- Loosen clamping screw 31a of the upper toothed quadrant and insert a wedge or small screwdriver into the screw slot.
- Check whether the sliding blocks 35 exist and are positioned correctly.
- The roller 45 must slip onto roller bolt 44.
- The two grooves of the hinged guiding block 46 must face to the top and the front. The guide groove 42 of the fabric rest plate must fit over guiding block 46.

The machine arm can now be removed.  
Also remove the fabric rest plate 43 to enable un-hindered access of the main control cam.

### Positioning the fabric rest plate and mounting the machine arm

Observe the following when mounting the fabric rest plate:

Before mounting the machine arm, check whether the guiding block 47 is located straight and whether its one groove faces up and to the front.

When finally mounting the machine arm, guide the feed lever 7 through slot 48 in the fabric rest plate.

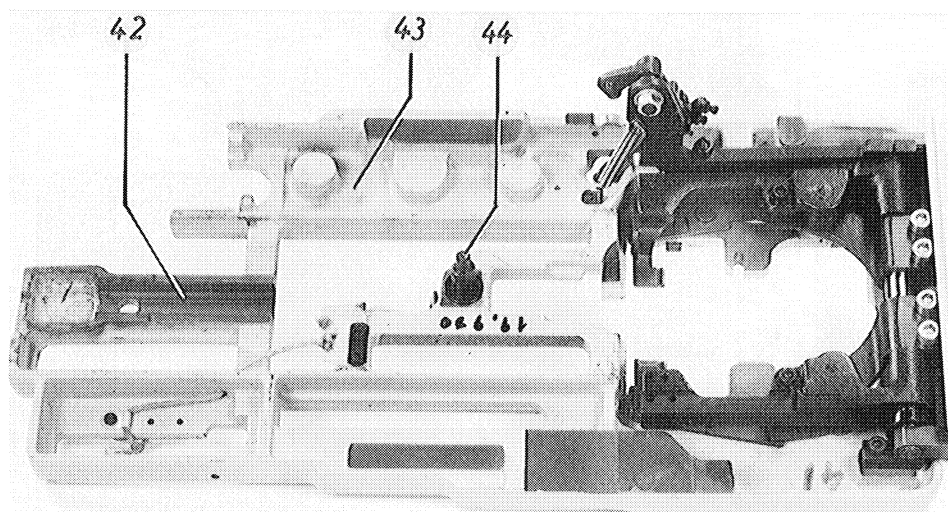
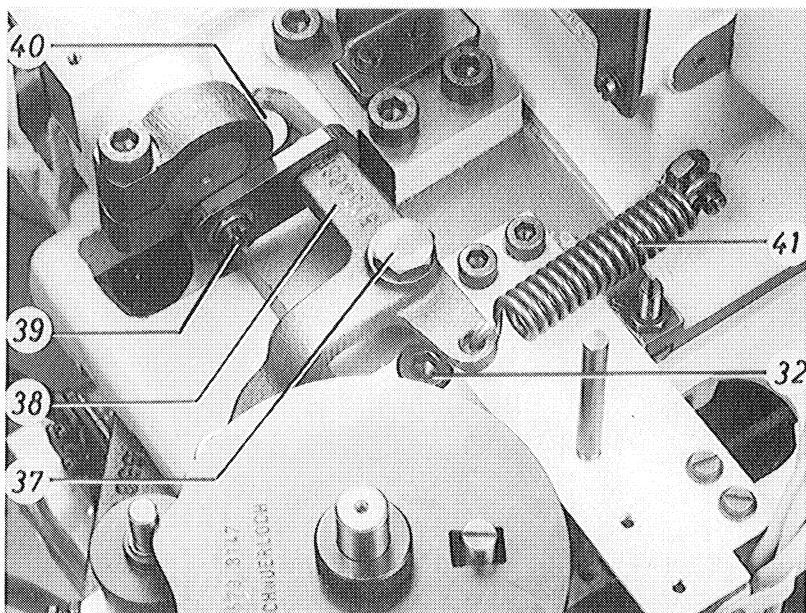

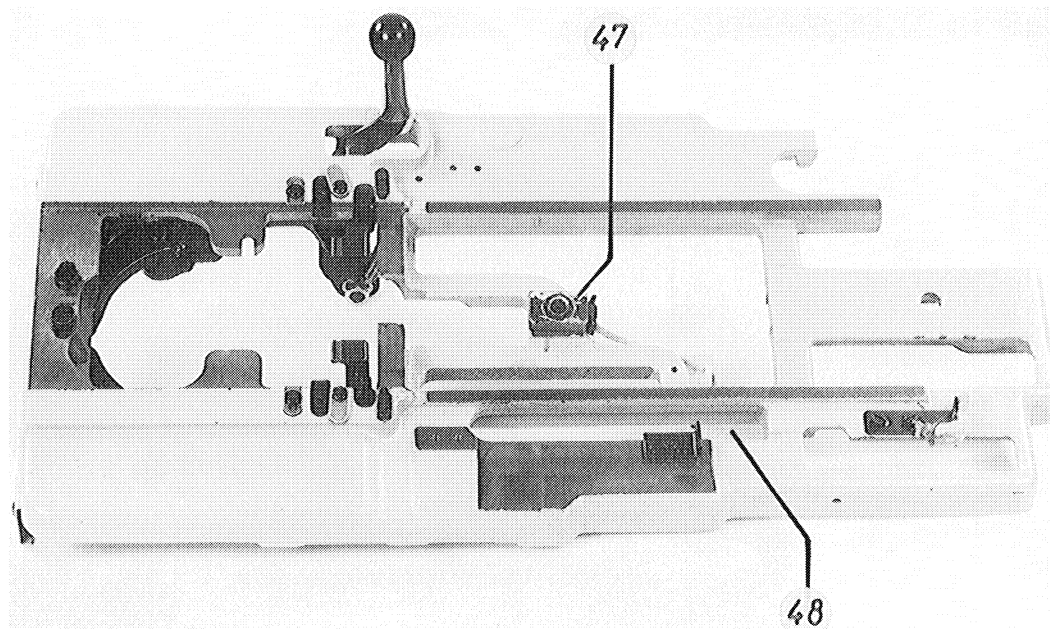
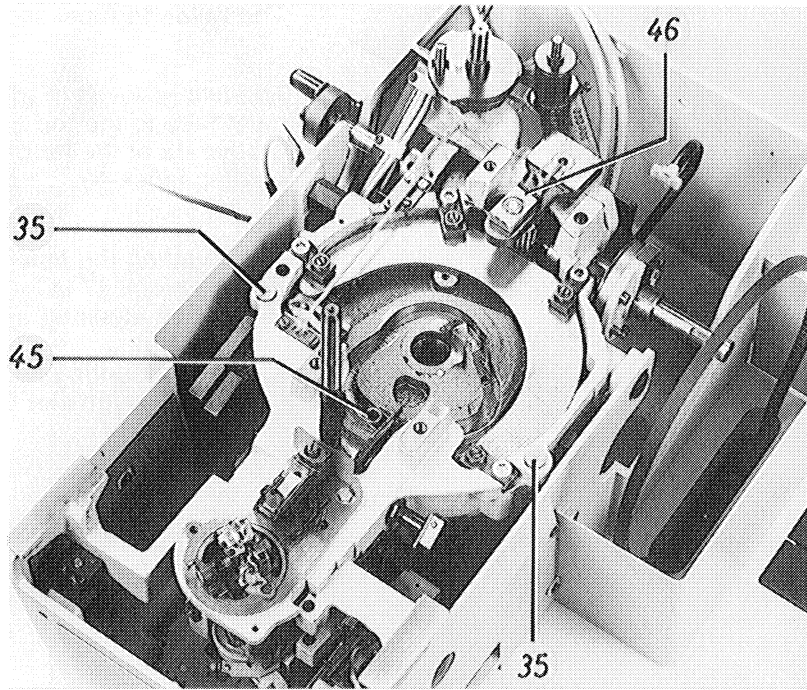



Before lowering the machine arm completely, insert the toothed quadrant 31 between cutting lever and arm underside.

As the guiding block 47 is hinged, it may get stuck, when the machine arm is lowered. Therefore, do not use force!

If necessary, lift the machine arm again, straighten the guiding block 47 and lower the machine arm again.

To fasten the machine arm and to mount the removed parts proceed as follows:

- Screw in the centering screw 40 and the three arm fastening screws 32. (Do not yet tighten).
- Insert the adjustment pin 33 as deep as possible so that it catches in the housing. Use a fork spanner to turn the adjustment pin in clockwise direction until it stops and tighten screw 34.
- First, tighten centering screw 40 and then the arm fastening screws 32. Thus, the machine arm is in its correct position.
- Move the proximity switch b10 up to a distance of 0.5 mm to the positioning disk 36 and tighten.
- Fasten the covers 6 and 15.
- Fasten the feed lever 7. To do this, insert the associated sleeve, place a washer each before and behind the lever and tighten screw 8. Hang in tension spring 9. Position the timing belt 11 and tension it with the belt tensioner 12 such that the belt centre can still be compressed by 4-6 mm. Tighten clamping screw 16, but not too securely. Check the smooth operation of the feed lever by turning timing belt pulley 17.
- Fasten the cover 24 for the oil felt.
- Fasten lever 38 with the screws 37 and 39. Hang in tension spring 41.
- Position all control cams and mount the shaft encoder 23.
- In the left and right end position of the toothed quadrant, when the looper block faces to the front or rear, an equal number of teeth should mesh with the gear.  
  
Mesh the upper toothed quadrant accordingly, position the oscillation bushing 31 parallel to the fabric rest plate according to section 17 and tighten screw 46.
- Position the timing belt 26 and mount the belt tensioner 28. For this, adjust the looper cam according to section 9. Tension the timing belt such that its centre can still be compressed by 6-8 mm by finger.
- Insert a needle and check the loop stroke according to section 2.3.2:
- Fasten the central plug-in connection 22 and re-clip all plug-in and marked cores on the clamping ledges. See also enclosed circuit diagram 798 700421B.
- Fasten the needle thread catcher with the screws 18 and 19 and check its adjustments as described in section 39. Re-establish the electric and compressed air connection to the solenoid valves.
- Check the centre of rotation of the looper as described in the following section 38.1.
- Re-fasten the cover to the control cams as well as the left, right and rear cover. Re-mount the synchronizer and handwheel.



## 38.1 Aligning the centres of rotation of needle bar and looper block

The machine arm has been aligned with the machine housing at the factory and is secured by centering screw 1 and adjustment pin 3 such that the centres of rotation of needle bar and looper block are aligned above one another.

This is the case when the clearance between needle and looper point remains constant during the rotation of needle bar and looper block. See detail A in the figure.

To check, turn the handwheel until the left looper point is located at the centre of the needle. Check clearances as follows:

1. At initial position of the looper block
2. when it has rotated by 90° by turning the hand crank and
3. when it has rotated by 180°.

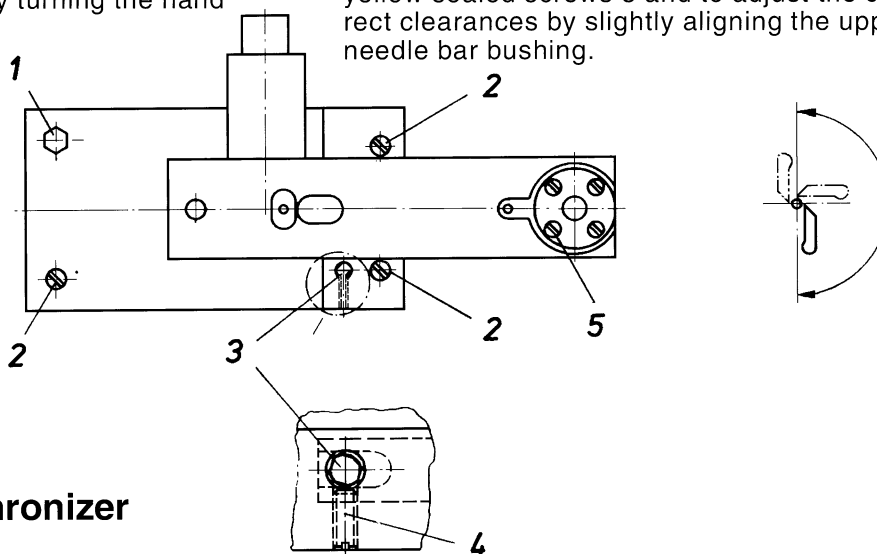

In the case of different clearances, proceed as follows:

- Loosen the fastening screws 2, the centering screw 1 and the lock screw 4 for the adjustment pin 3.
- Re-tighten centering screw 1 and then loosen slightly. Turn the adjustment pin 3 in clockwise direction until it stops and tighten securely with lock screw 4. (See detail B). First, tighten the centering screw 1 and then the fastening screws 2.
- If another check still shows different clearances, it is allowed as an exception to loosen the yellow sealed screws 5 and to adjust the correct clearances by slightly aligning the upper needle bar bushing.

## 39. Adjusting the synchronizer

If at a machine stop the needle bar rises from its right puncture, it should position 2-1 mm before its upper dead point.

The distance between disk 3 and proximity switch b10 should be 0.5 mm.

- Fasten the synchronizer 1 on the arm shaft such that its groove fits over pin 2 at the housing.

- First, with the needle bar in its upper position, turn disk 3 on the left arm shaft end such that its cutout is opposite proximity switch b10.

- To check the position start the automat and let it run until it stops. If necessary, correct the position of disk 3.
- This positioning shortly before the upper dead point makes sure that the loading space between needle and cloth clamps is never too small, which might be the case due to tolerances of the synchronizer.

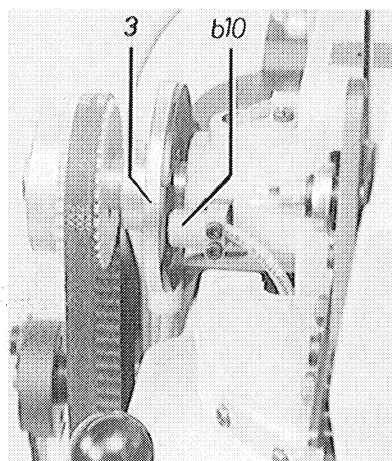
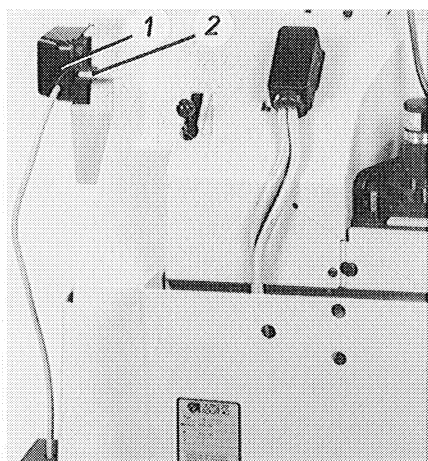



## 40. Electropneumatic needle thread catcher

Subclass 578-121000 features the needle thread catcher as a standard.

All other subclasses except for the -114000 can optionally be retrofitted with the electropneumatic needle thread catcher, order no. 578 20003.

If, however, the 578-131393 is equipped with the set of parts "upper gimp guide", order no. 578 5101, it cannot be mounted.

The needle thread catcher catches the needle thread immediately after the thread has been trimmed, clamps it, and lies it down into the right lip when sewing the next buttonhole.

This offers the following advantages:

- Secure seam beginning, also in light, loose fabrics.
- Tight stitches at the seam beginning.
- No necessity for manual needle thread trimming, as the buttonhole lip is sewn over the thread tail at the seam beginning.

### Sequence of functions

- After the automat has been started the needle thread catcher with the clamped thread descends onto the material. This is actuated via solenoid valve s13 (thread catching 1) and cylinder 2. Simultaneously, the opener 4 is swivelled sideways via solenoid valve s16 (thread catching 3) and cylinder 3. The thread catcher stays closed.
- Corresponding to the given sewing length the sewing cycle starts and commences with the right buttonhole lip.

The needle thread tail laid down by the thread catcher is sewn over and vanishes in the lip.

- After a certain period of time that is determined in the control, the thread catcher moves back to its upper position.

This prevents the thread catcher from hitting the right clamp bow 5.

- The thread catcher swivels from the lay-down position into the catch position that is, from the right to the left buttonhole lip via solenoid valve s15 (thread catching 2) and cylinder 1.
- At the end of the left buttonhole lip the needle positions in its upper position. The needle thread is trimmed.

The thread catcher descends via s13 (thread catching 1) and cylinder 2.

The opener lever 6 slides onto opener 4, thereby opening the thread catcher, which is then swivelled towards the needle through cam sheet 7 to catch the thread.

With further downward motion of the thread catcher, the opener lever 6 slides off the opener 4. The thread catcher closes. The solenoid valve s13 vents and the thread catcher with the clamped thread moves back to its upper position.

During this, the opener lever 6 slides along behind the opener 4 without being actuated.

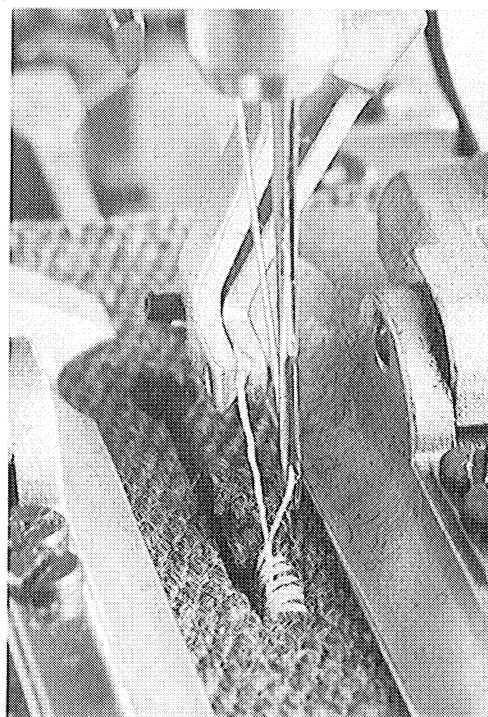
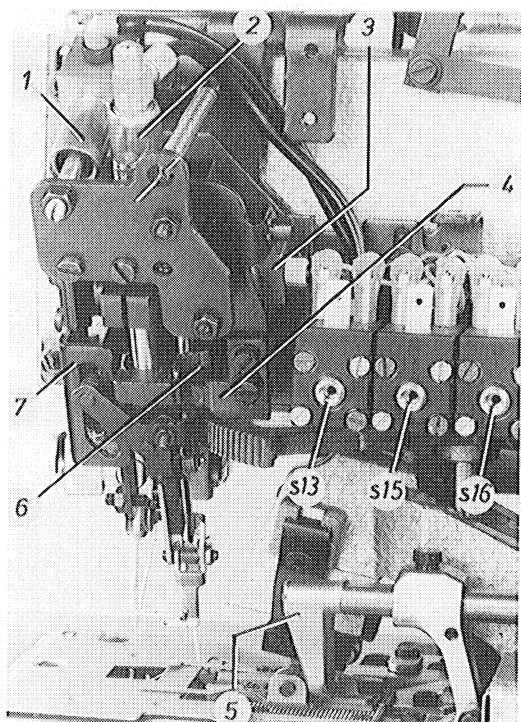

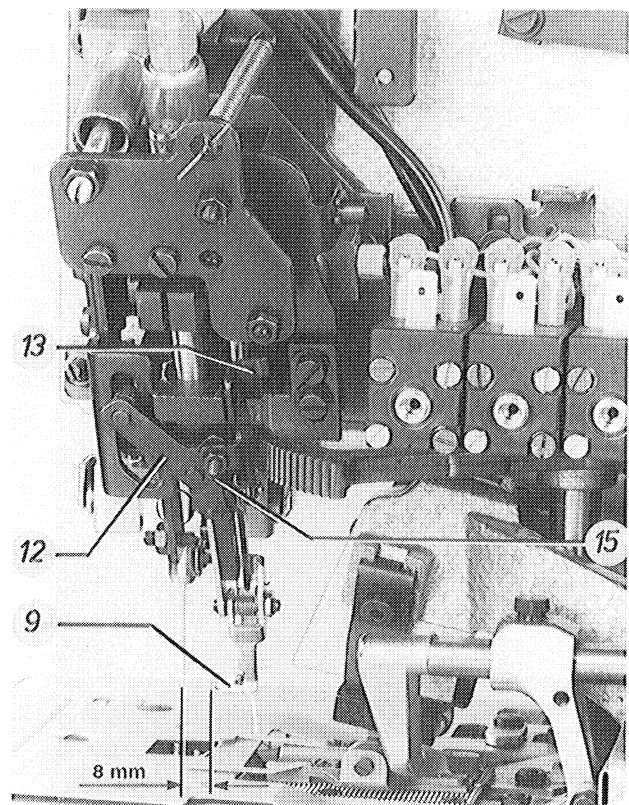
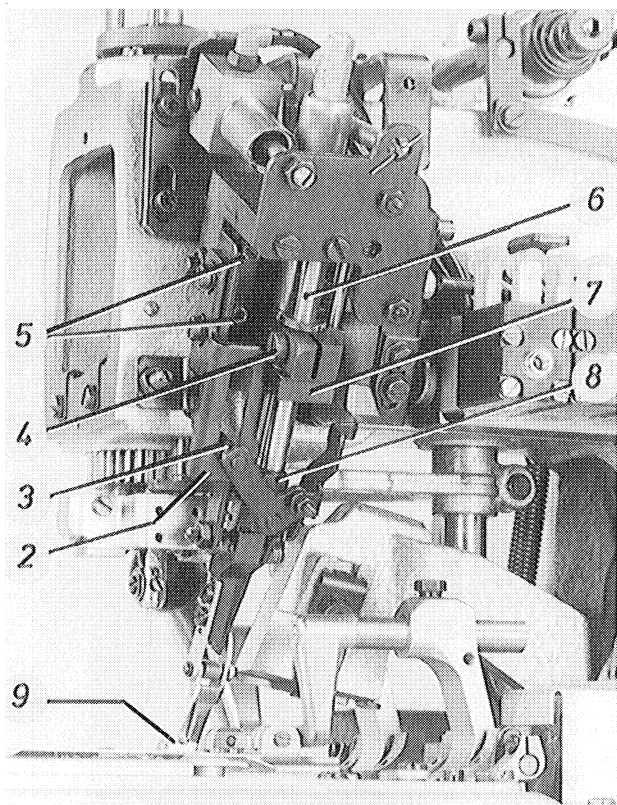
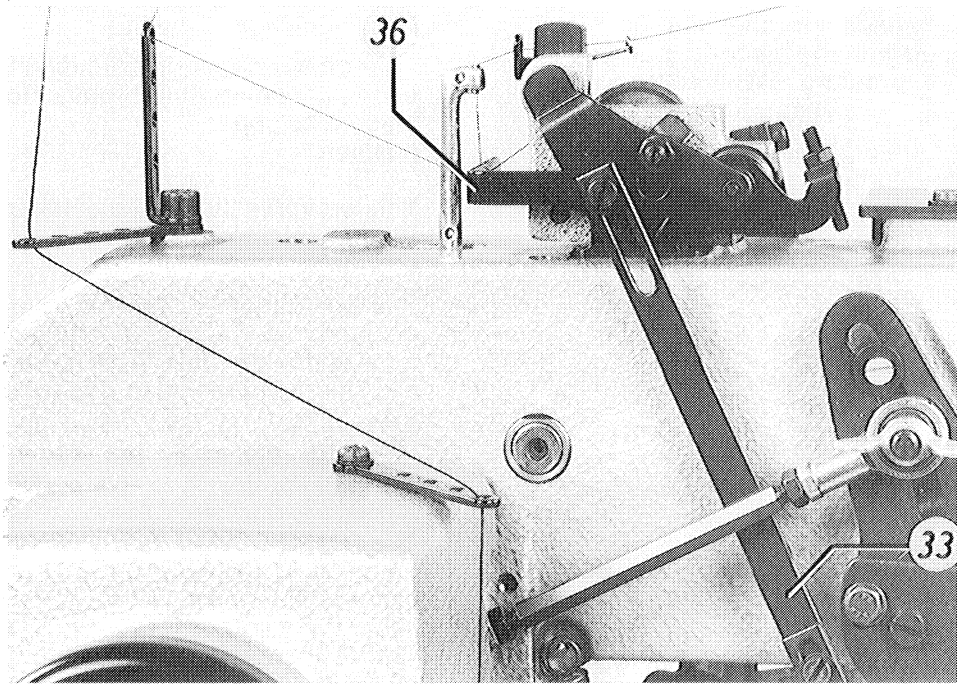



## Adjusting

To avoid damage to the needle thread catcher, make adjustments with **turned off motor protection switch** and pulled out compressed air line.

When the sewing automat is equipped with a needle thread catcher the needle thread puller 36 must at first be brought into a certain pre-adjusted position.

When the cutting block rests on the knife, the puller 36 must be parallel to the upper side of the machine arm. Adjust rods 33 accordingly.

For the later adjustment of the timing of catching and trimming action in the programmes 48 and 49, this pre-adjustment enables to obtain an average setting so that adjustments can be made into the lower or upper range.

After removal of the cutting block and positioning of the clamping plates, proceed as follows for adjusting the needle thread catcher:

- Position cam sheet 2 parallel to rod 6. Loosen screws 5 and align.
- The distance between clamping block 8 and guide block 7 should be 2 mm. Loosen clamping screw 4 and adjust rod 6 accordingly.

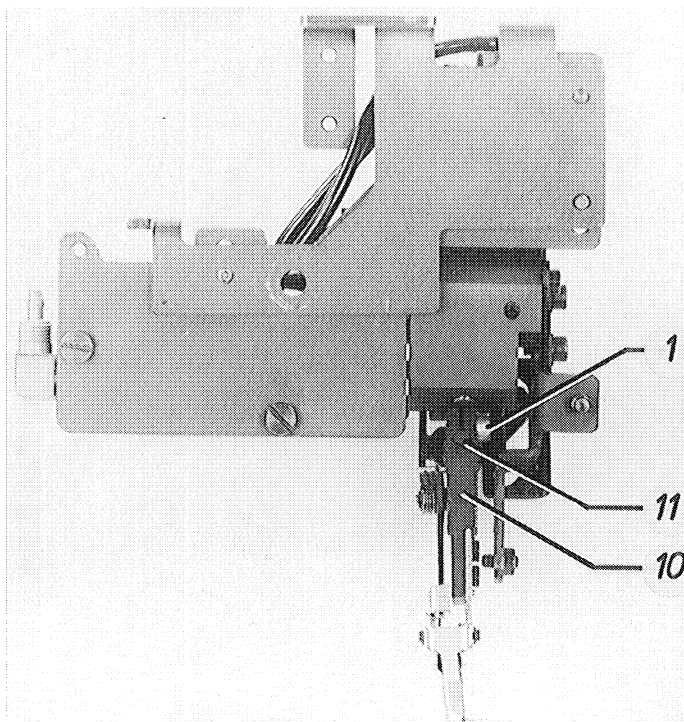

Before tightening the clamping screw 4, turn clamping block 8 such that

- a) the roller 3 slightly moves in the cut-out of the cam sheet and
- b) the thread clamp 9 of the needle thread catcher is aligned in the direction of sewing, if possible.

- When the needle thread catcher is in its rest position a clearance of 8 mm should be between the points of clamps 9 and the front of the needle.

Loosen screw 1 and swivel the catcher piece 10 accordingly onto bolt 11.

Before tightening screw 1, set the catcher piece 10 tight such that only a drop of oil can pass. To achieve this, press against lever 12.

- With closed thread clamp 9 the clearance between opener lever 13 and angle 14 of the movable clamp must be 0.3 mm.

Adjust the opener lever 13 accordingly using set screw 15.

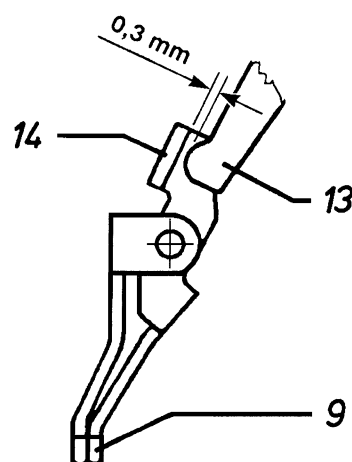

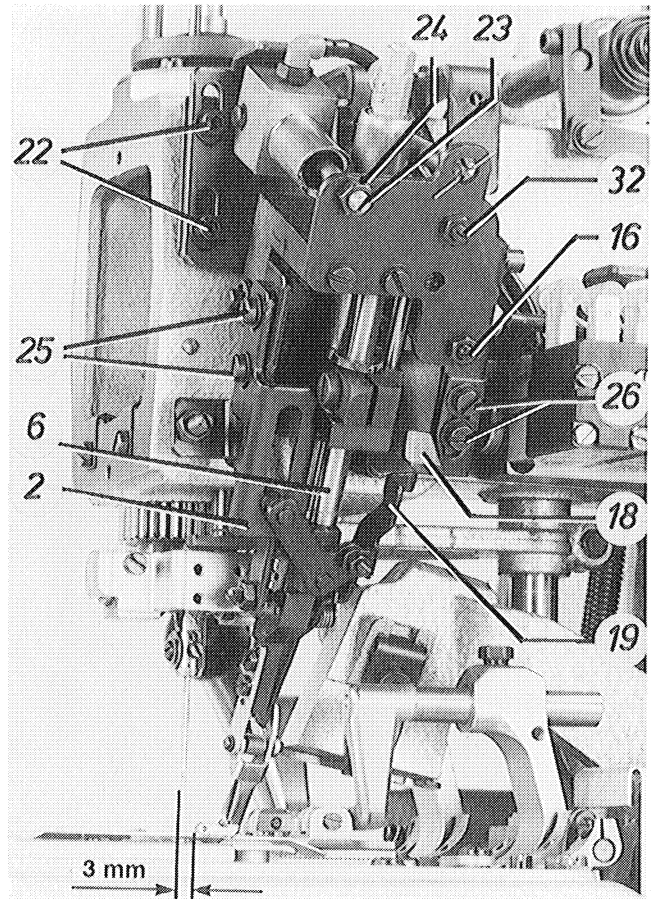
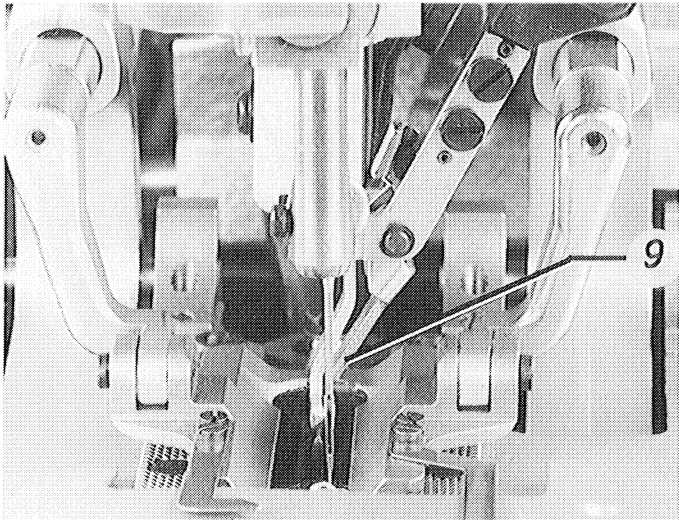
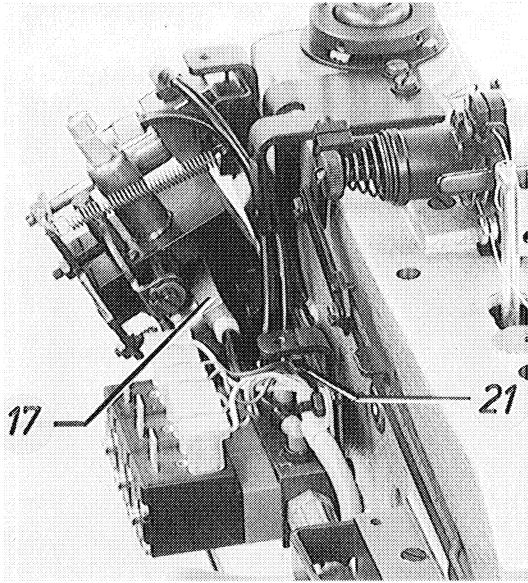



- During the downward motion of the thread clamp into its thread lay-down position, opener 18 is swivelled sideways by cylinder 17. The opener lever 19 should descend unhindered behind the opener 18.

Adjust set screw 16 accordingly and check the unhindered motion of the opener lever 19 with manually pulled forward opener 18.

- With needle puncture on the right and lay-down position of the lowered thread clamp, the right side of the thread clamp 9 should be located behind the right side of the needle seen in the direction of sewing. See figure. Hold the opener piece 18 in its sideways swivelled position and lower the catcher into its lay-down position.

Rotate piston rod 23 to reach the lay-down position. Lock the nut 24.

- The distance between the lowered thread clamp and the material should be 3-4 mm.

This adjustment is appropriate for medium weight material. Thicker and thinner material may require a correction. Place the material under the cloth clamps. Loosen screws 21 and 22 slightly. Hold the thread catcher in its lowered and right position.

- Adjust the distance by raising or lowering the thread catcher assembly. Tighten screws 21 and 22. Make sure that the previously adjusted distance of 8 mm between the points of clamp 9 and the needle is unchanged.

- Just before the thread clamp reaches its bottom position, it is swivelled toward the needle through cam sheet 2. Then, the distance to the needle should normally be 3 mm. With thick fabrics and short sewing lengths, eg 10 or 12 mm a distance of 5 mm is necessary to prevent the needle bar from hitting onto the catcher points.

After loosening screws 25, accordingly raise or lower the cam sheet 2. Make sure that the cam sheet is positioned parallel to rod 6.

- The opening width of the thread clamp should be approx. 4 mm. By turning set screw 32, the opener 18 can be placed more or less into the path of the opener lever 19.

- Thread clamp 9 should close just before the thread catcher reaches its bottom position.

Loosen screws 26 and adjust the height of the opener 18 such that the descending opener lever 19 slides off just before it reaches its bottom position.

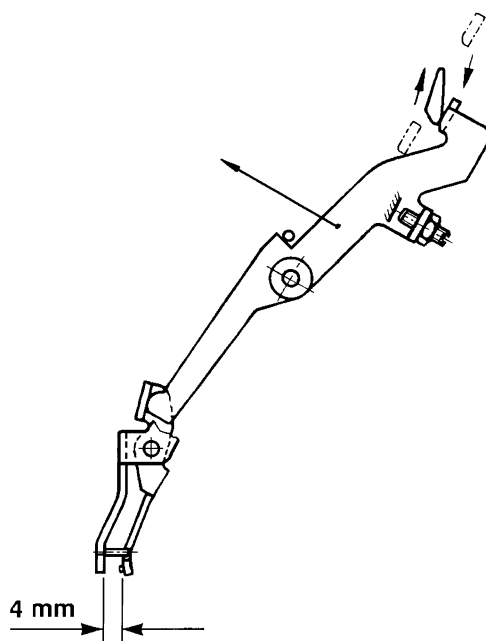

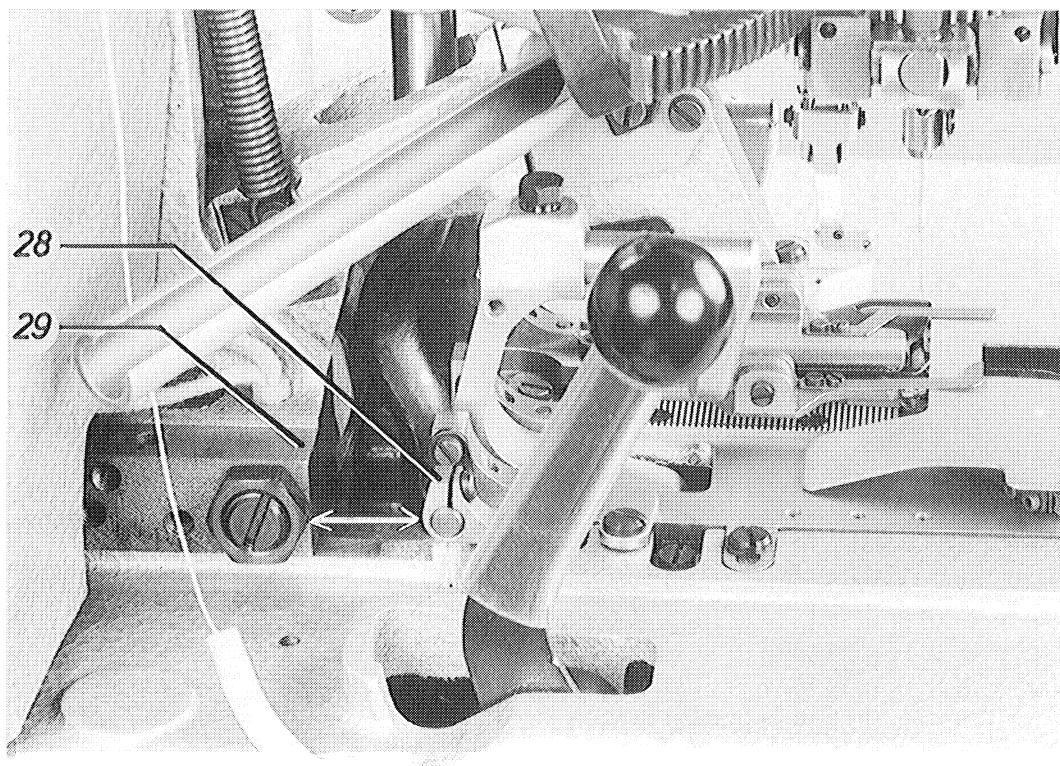
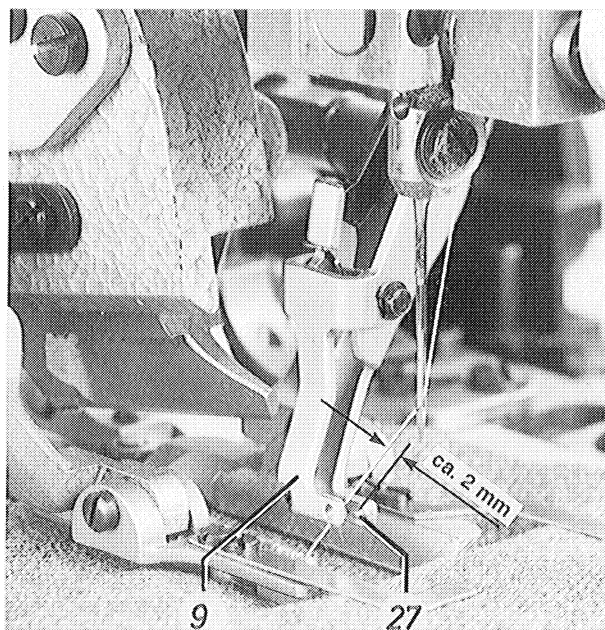
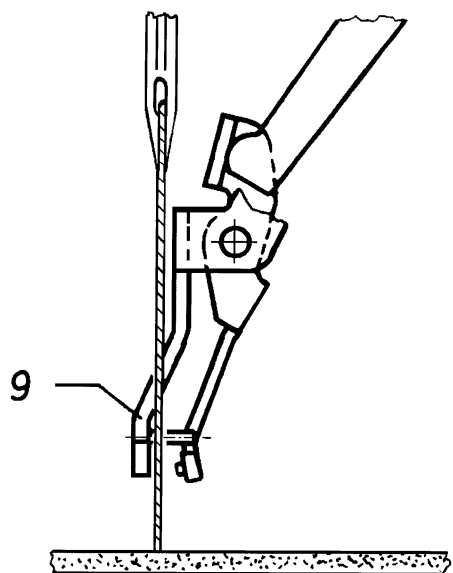



- After the left buttonhole lip is sewn, the thread clamp 9 must be positioned in the exact needle thread catching position.

With lowered and opened thread clamp the needle thread should be located close to the left leg of the clamp. See sketch.

When the swivel motion of the catcher toward the needle is completed, pin 27 should have moved beyond the needle thread by approx. 2 mm.

Turn on main switch and motor protection switch.

Enter programme 50 at the switch "programme" and activate by STOP-push button.

After pressing down the pedal, the automat moves into the seam beginning position. By again pressing down the pedal a cycle is sewn up to the end of the left buttonhole lip.

In this position turn off main switch.

- Use the crank to turn the fabric rest plate by 16 mm into the catching position. It is advisable to measure the distance between guide block 28 and machine arm 29.

If this distance is eg 21.5 mm, one subtracts 16 mm and obtains a distance of 5.5 mm. Move the guide block accordingly toward the machine arm.

With lowered and opened thread clamp turn stop screw 30 such that the needle thread is located close to the left leg of the clamp. Tighten lock nut.

- When the thread clamp is swivelled into its furthest forward position, the safety screw 31 must be turned in until it stops and then secured with a lock nut. In the case of snarled threads this prevents the thread clamp from being pulled towards the needle.

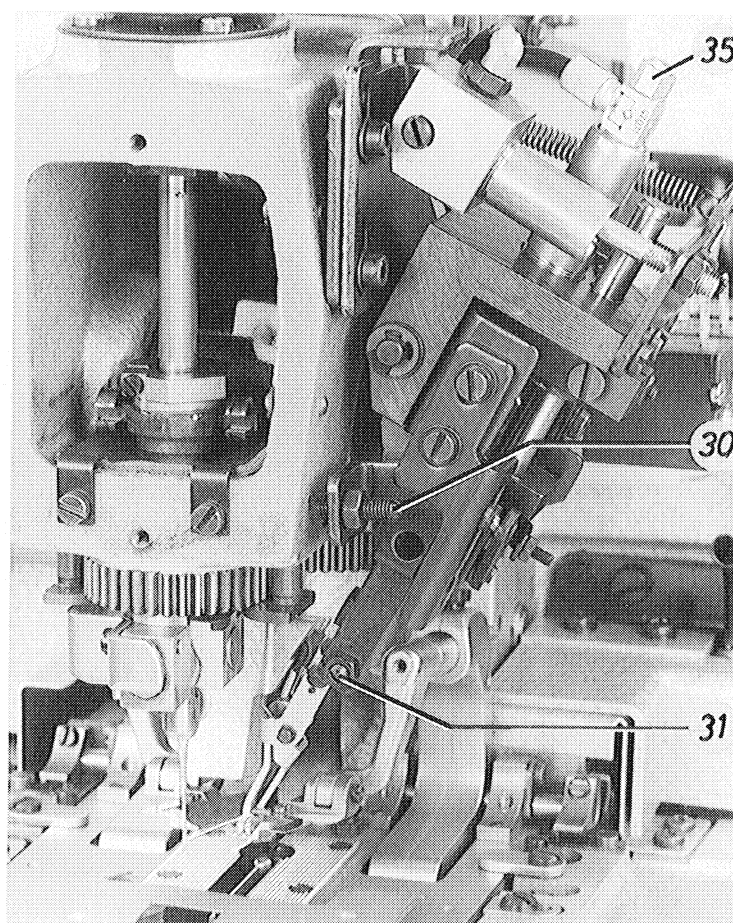



- The downward motion of the needle thread catcher should be speedy, but not abrupt. Regulate throttle valve 35 accordingly (see figure on page before).
- The length of the thread tail at the buttonhole end is adjusted in programme 48.
- Secure catching of the needle thread up to behind pin 27 is adjusted in programme 49.

The length of the thread tail to be laid down and sewn over should by no means exceed the length of the straight part of the right buttonhole lip.

Enter programme 48 or 49 at the switch "programme" and activate by the STOP-push button.

A numerical value in the display may be increased or decreased by pressing down the pedal.

Basic principle: The higher the numerical value, the later the catching and trimming.

To check the catching and lay-down motions, test seams may be sewn in programme 48 or 49 by pressing key  $\Sigma$  "setting counter".

**Note!**

On the 578-131000 the thread catching function can only be activated up to a sewing length of 32 mm, and on the -151000 only up to a sewing length of 38 mm.

In the case of sewing lengths exceeding the above values, the needle thread catcher is automatically deactivated.

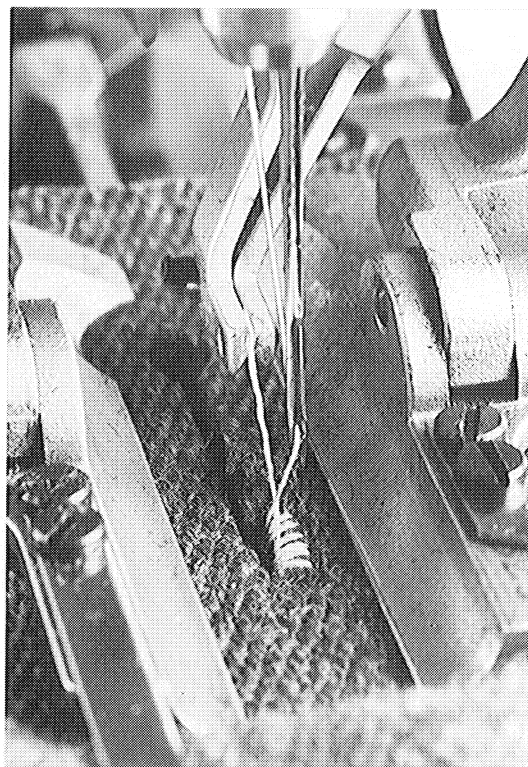
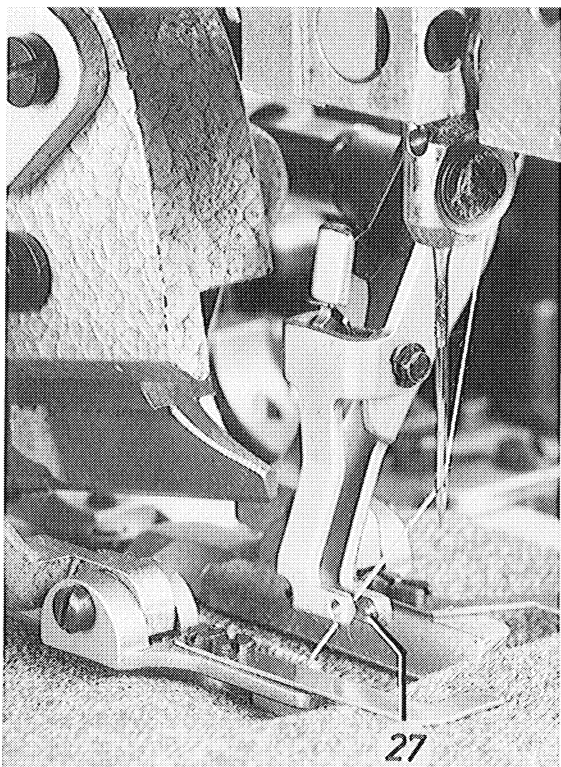



## 41. Electropneumatic looper thread puller for unwinding the looper thread from the thread stand



Turn off main switch!

Subclass -121000 can be optionally equipped with the electromagnetic looper thread puller, order no. 578 20601.

Its application is especially recommended for sewing thick and stiff looper threads with thicknesses up to Nm 30, eg for buttonholes with handwork appearance.

To enable a sufficiently long loose looper thread tail and to assure that the buttonhole lip is not too firm-

ly tightened at the seam end and is not distorted, lever 2 pulls looper thread from the cone already during the sewing cycle.

In the end position of the automat lever 2 should be aligned with pipe 1 and thread guide 3 and should not deflect the thread.

The deflection of the lever is determined by the position of the cylinder 4.

The motion of the lever 2 must not be abrupt. It must be regulated at the throttle valve 5 such that the adjusted deflection is obtained at the end of the sewing cycle (end of the left buttonhole lip).

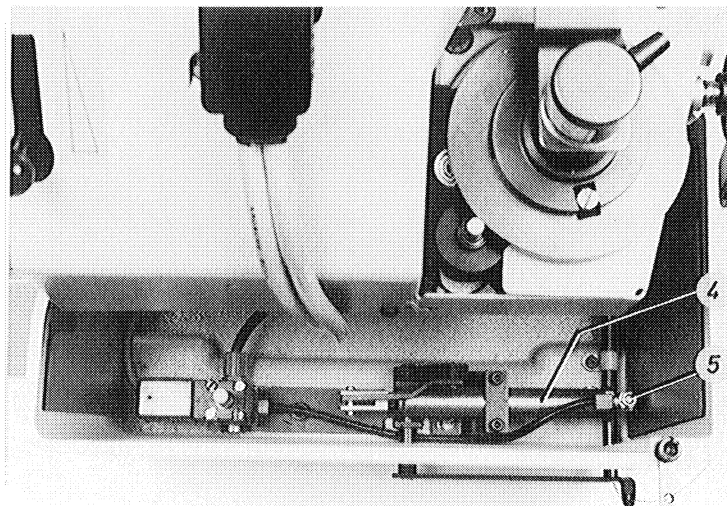
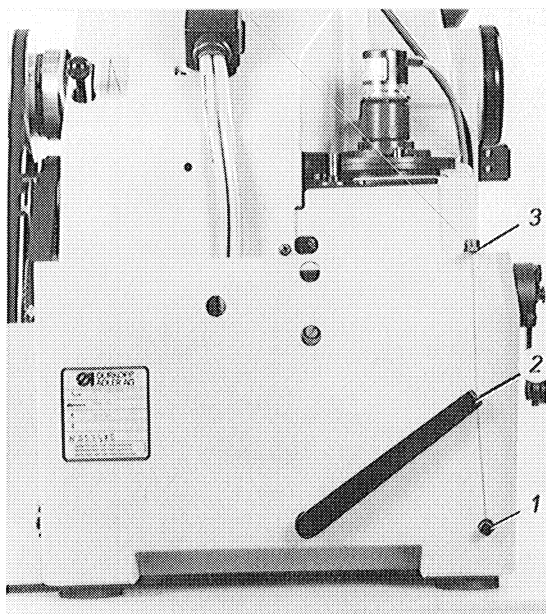



## 42. Electropneumatic looper thread laying device

This device sucks in the looper thread tail after the thread has been trimmed and lays it into the buttonhole lip at the beginning of the next sewing cycle.

The buttonhole beginning is, therefore, always neat.

The looper thread tail should be long enough to assure that it is sewn into the lip approx. up to the buttonhole eyelet. Should the thread tail be too long, it can emerge at the buttonhole eyelet. The tail length is adjusted during test sewing, using set screw 7.

The subclass -112000 (round tack) and -113000 (cross tack) feature the looper thread laying device, order no. 578 20701, as a standard.

It can be retrofitted on the older versions of the subclasses -112000 and -113000 and on the -141000. To operate the machine, the electropneumatic needle thread catcher, order no. 578 20003, is required.

### Function

After the buttonhole end and before the thread is trimmed, the thread puller is actuated via the solenoid valve s21 and loose thread is pulled forward so that it can be sucked in by the looper thread laying device.

At the same time with the transport motion of the fabric rest plate, the solenoid valve starts to suck in the thread and stops again when the first stitches have been sewn.

At the buttonhole end, the vacuum is switched on again and is activated until the fabric rest plate comes to a standstill.

The timing of the machine functions is determined in the control and cannot be changed.

- In the initial position, the eye of the thread puller should be located above the thread pipe 2. When the thread puller rests against the pin 3, adjust the angle 4 accordingly.
- In the initial position of the automat the distance between lever 5 and pin 6 should be 0.2 mm.  
Loosen the screw 8.  
When the clamping piece 10 rests on piston rod 9, rotate the rod 11, until the distance is 0.2 mm.  
Tighten screw 8.

- Loosen the screws 13 and position the suction pipe 12 as close as possible to the throat plate, as shown in the figure. Make sure to observe
    - a) that the rotating throat plate does not hit anything and
    - b) that the suction pipe 12 is not touched by the lower cloth clamps during the transport motion of the fabric rest plate.
  - Adjust an operating pressure of 6 bar at the maintenance unit.
- Please note!**  
The suction pipe must be connected to non-lubricated air.
- Regulate the throttle valve 15 such that the motion of the looper thread puller 1 is speedy, but not abrupt and uncontrolled.

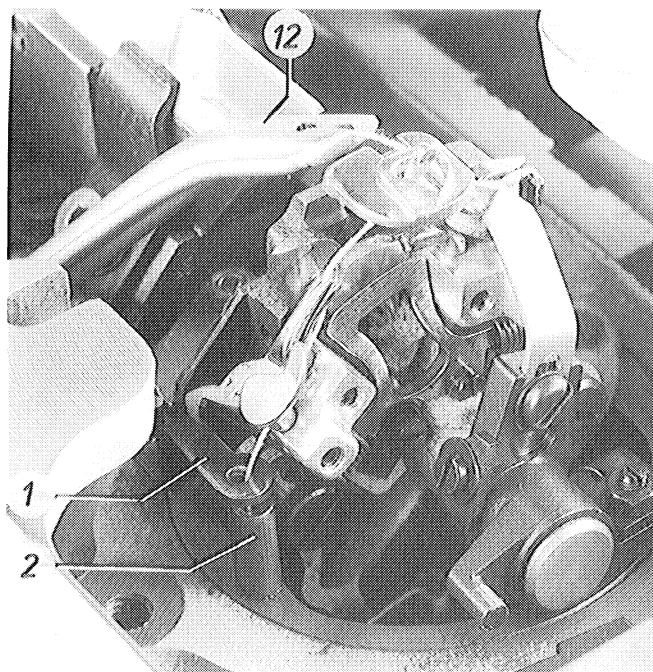

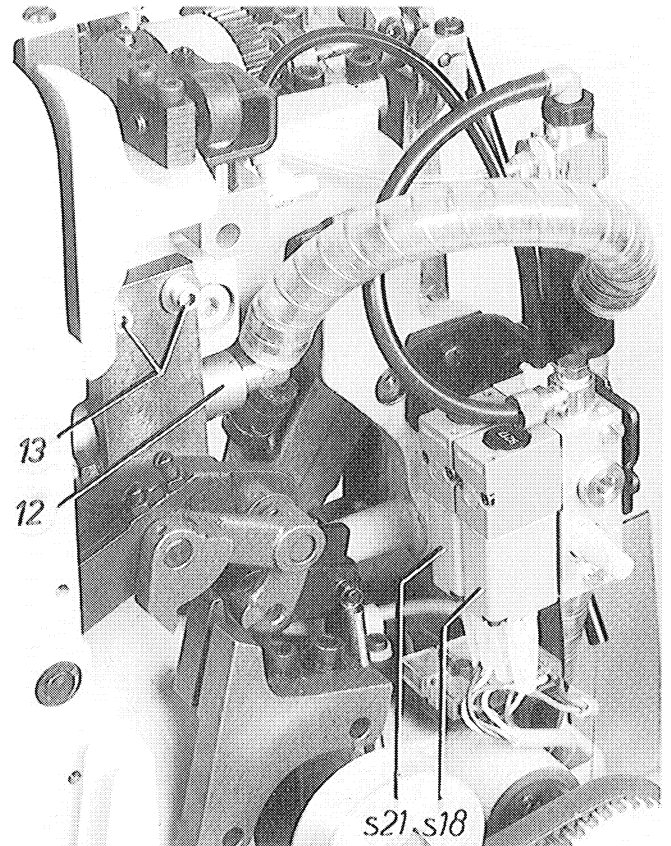
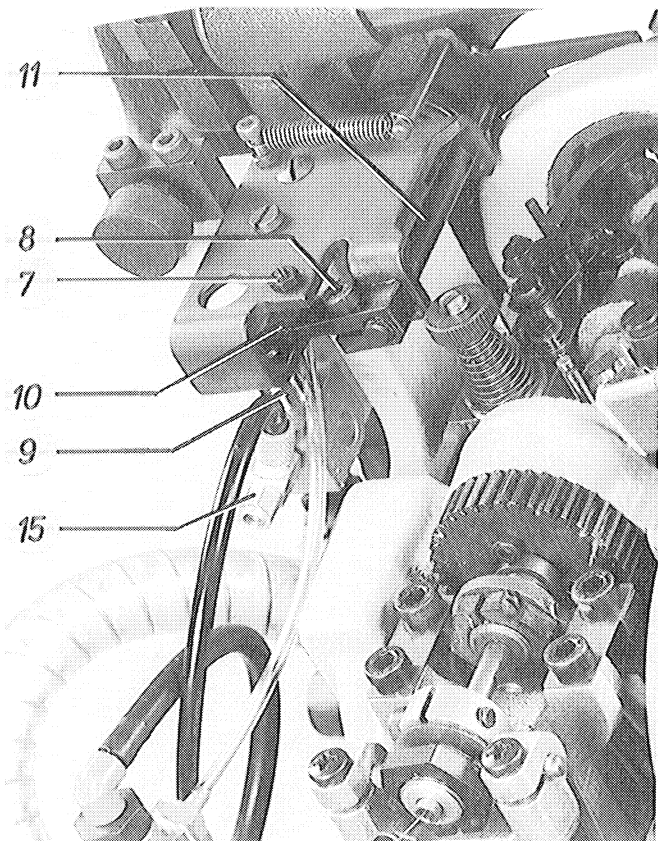
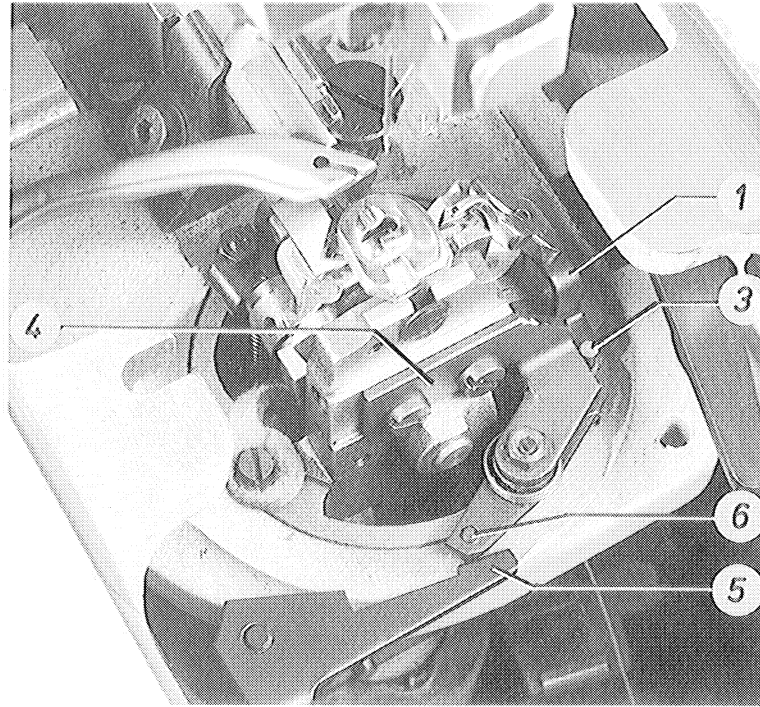

Hinweis für Umschaltung auf  
 andere Netzspannungen beachten  
 Observe the instructions in chapters  
 to other mainwritings

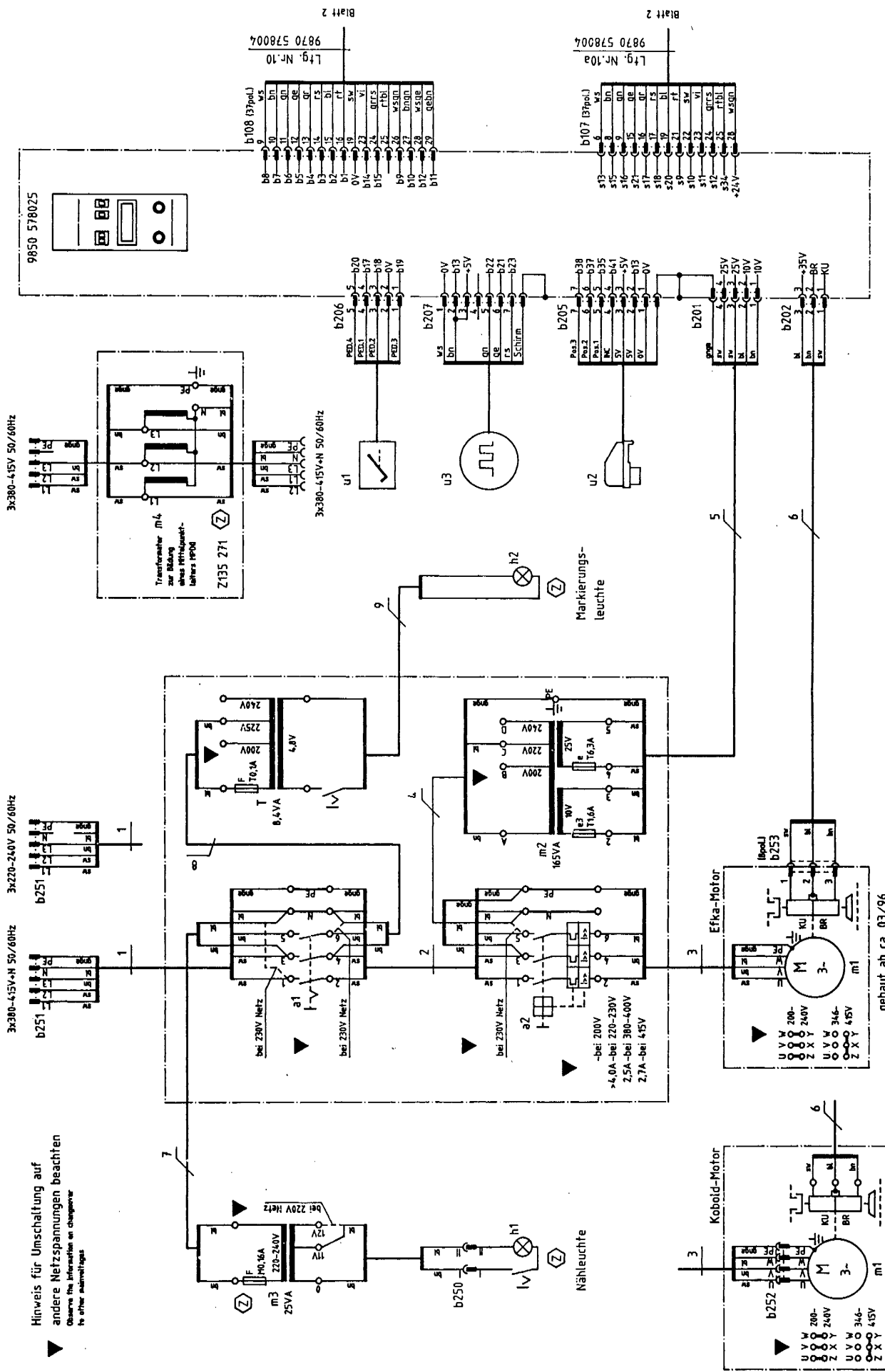

Blatt		1/2	
Bauschaltplan		9890 578001 B	
Klasse 578			
Teilerfamilie		DÜRKOPP ADLER AG Bielefeld	
Freigabe		0365 / 92	
c	Datum	23.10.92	
b	02.0	20.02.96	Handarb. Harder
a	01.0	14.09.93	Krüger Gepr. <i>Boys</i>
Änderung		Datum	Name
Datum		Name	Norm

gebaut bis ca. 02/96

gebaut ab ca. 03/96

Blatt 2  
Lfg. Nr. 10a  
9870 578004

Blatt 2  
Lfg. Nr. 10  
9870 578004

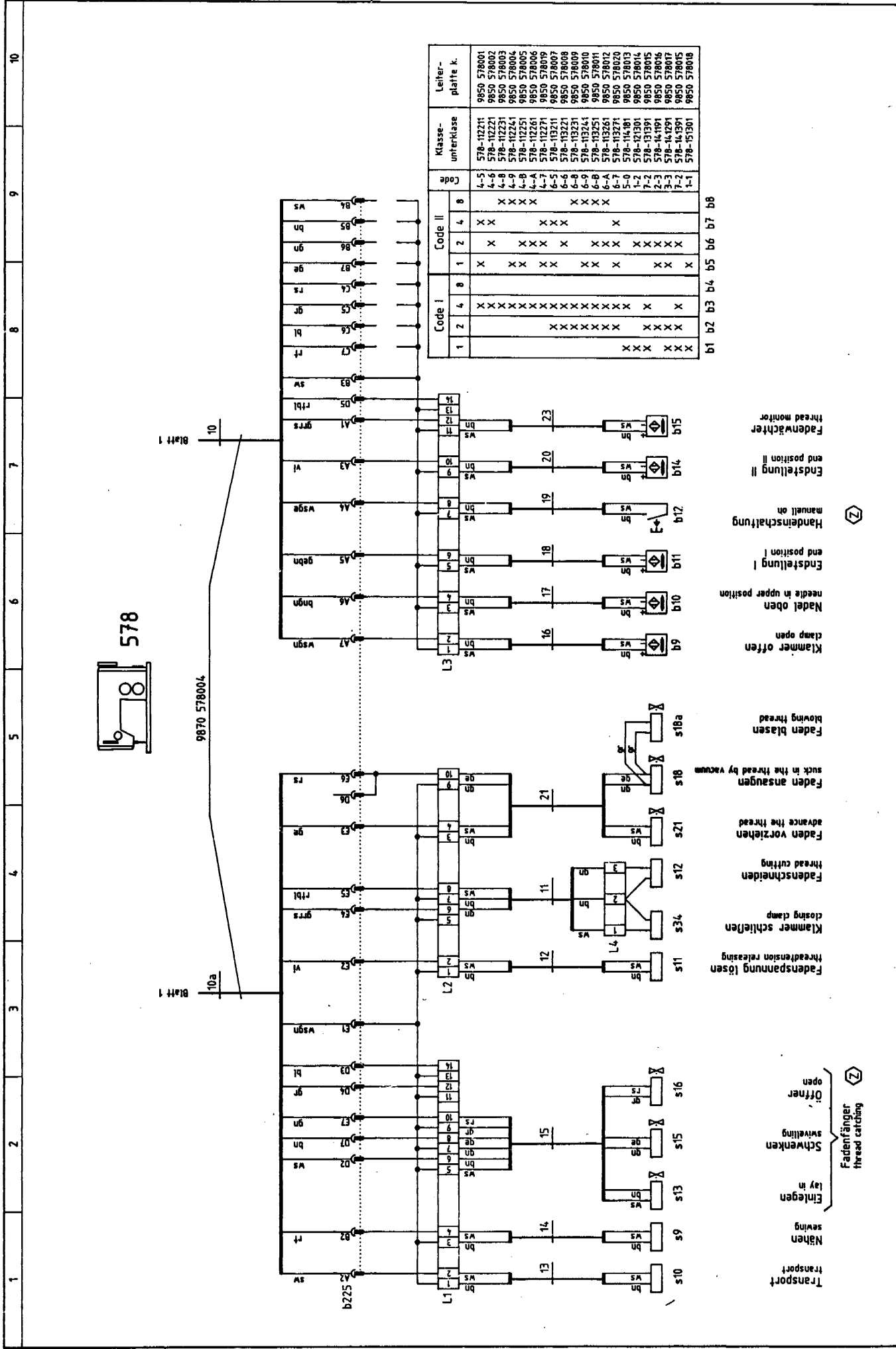

Code	Code I	Code II	Klasse- unterklasse	Leiter- platte k.
1	2	1	578-11221	9850 578001
2	4	2	578-11221	9850 578002
3	4	4	578-11223	9850 578003
4	4	8	578-11223	9850 578004
5	4	8	578-11225	9850 578005
6	4	8	578-11251	9850 578006
7	4	8	578-11251	9850 578007
8	4	8	578-11251	9850 578008
9	4	8	578-11251	9850 578009
10	4	8	578-11251	9850 578010
11	4	8	578-11251	9850 578011
12	4	8	578-11251	9850 578012
13	4	8	578-11251	9850 578013
14	4	8	578-11251	9850 578014
15	4	8	578-11251	9850 578015
16	4	8	578-11251	9850 578016
17	4	8	578-11251	9850 578017
18	4	8	578-11251	9850 578018
19	4	8	578-11251	9850 578019
20	4	8	578-11251	9850 578020
21	4	8	578-11251	9850 578021
22	4	8	578-11251	9850 578022
23	4	8	578-11251	9850 578023
24	4	8	578-11251	9850 578024
25	4	8	578-11251	9850 578025
26	4	8	578-11251	9850 578026
27	4	8	578-11251	9850 578027
28	4	8	578-11251	9850 578028
29	4	8	578-11251	9850 578029
30	4	8	578-11251	9850 578030
31	4	8	578-11251	9850 578031
32	4	8	578-11251	9850 578032
33	4	8	578-11251	9850 578033
34	4	8	578-11251	9850 578034
35	4	8	578-11251	9850 578035
36	4	8	578-11251	9850 578036
37	4	8	578-11251	9850 578037
38	4	8	578-11251	9850 578038
39	4	8	578-11251	9850 578039
40	4	8	578-11251	9850 578040

<b>Bauschaltplan</b>		<b>Blatt 2/2</b>	
<b>Klasse 578</b>		<b>Oberteil</b>	
<b>DÜRKKOPP ADLER AG</b>		<b>Freigabe 0365/92</b>	
<b>Bielefeld</b>		<b>0365/92</b>	
		<b>Teilfamilie</b>	
<b>c</b>	<b>Datum</b> 23.10.92	<b>Harder</b>	<b>Gepr.</b>
<b>b</b> 02.0	<b>20.02.96</b>	<b>Harder</b>	<b>Gepr.</b>
<b>a</b> 01.0	<b>14.09.93</b>	<b>Krüger</b>	<b>Gepr.</b>
<b>Änderung</b>	<b>Datum</b>	<b>Name</b>	<b>Norm</b>

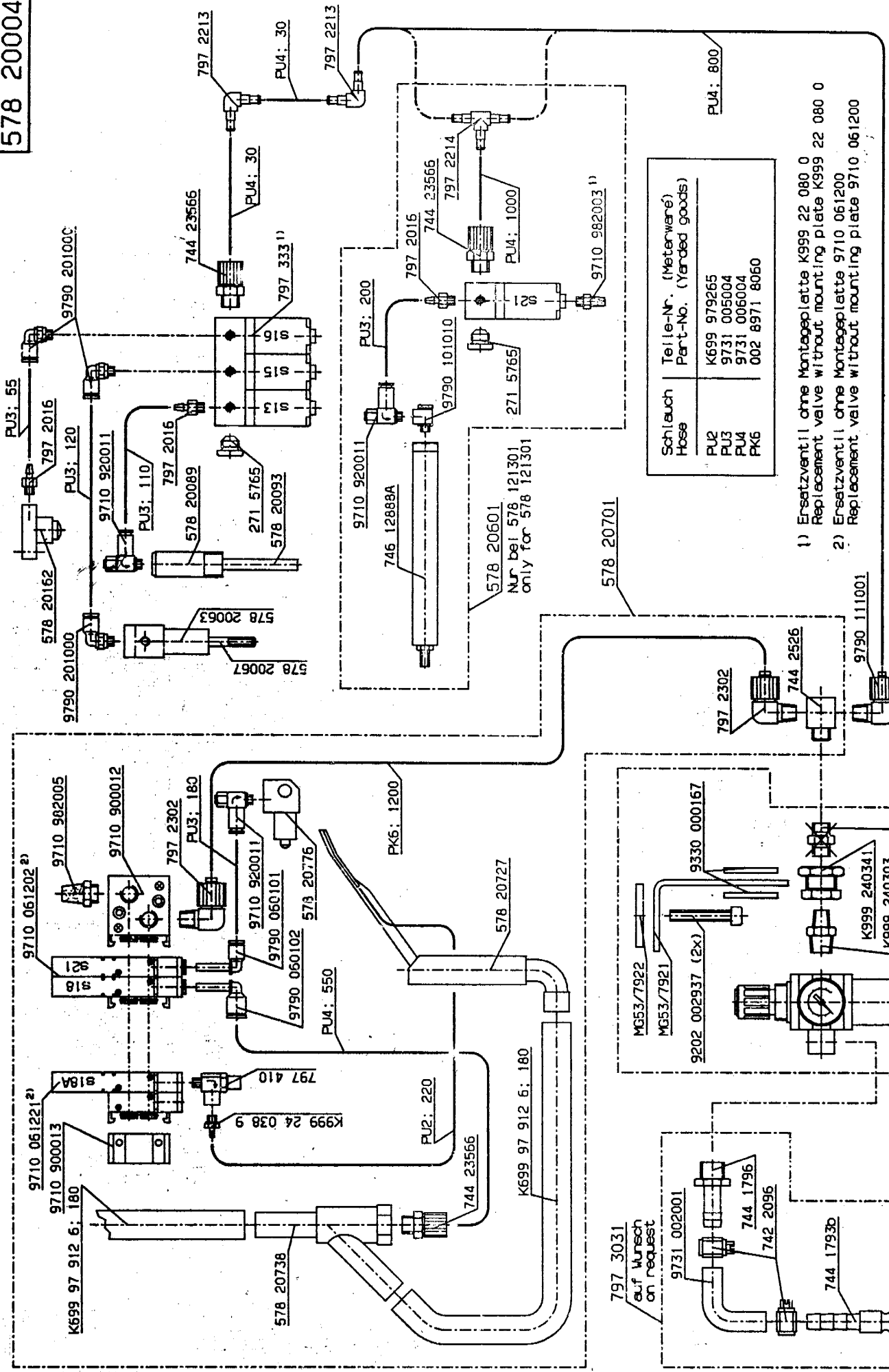

Schlauch Hose	Teile-Nr. (Meterware) Part-No. (Yarded goods)
PU2	K699 979265
PU3	9731 005004
PU4	9731 006004
PK6	002 8971 8060

- 1) Ersatzventil ohne Montageplatte K999 22 080 0  
Replacement valve without mounting plate K999 22 080 0
- 2) Ersatzventil ohne Montageplatte 9710 061200  
Replacement valve without mounting plate 9710 061200

578 20601  
Nur bei 578 121301  
only for 578 121301

797 3031  
auf Wunsch  
on request



Tag	12.9.91	gez.	Schuld.	gez.	Maß.	gez.
Pneumatik-Geräteplan für 578 121301 und 578 20003						
Pneumatic-Elements-Plan for 578 121301 and 578 20003						
04.0	11.07.96	Schuld.				
And.	Tag	gez.				

9780 000108  
auf Wunsch  
on request

